

JIANGSU HUAJIE STAINLESS STEEL PRODUCTS CO.,LTD

Established in 2002

JIANGSU HUAJIE

<http://www.jshjbxg.com>

Tel:0086-523-83901012

Fax:0086-523-83784202

Email:sales1@jshjbxg.com



POINT-FIXED GLASS WALL FITTINGS TYPICAL PRODUCT CATALOG

POINT-FIXED GLASS WALL FITTINGS
TYPICAL PRODUCT CATALOG

Finish to stainless
steel spiders



Satin



Mirror



Pearl sand finish

IN ARCHITECTURAL GLASS FITTINGS

Fluorocarbon coated stainless steel spiders

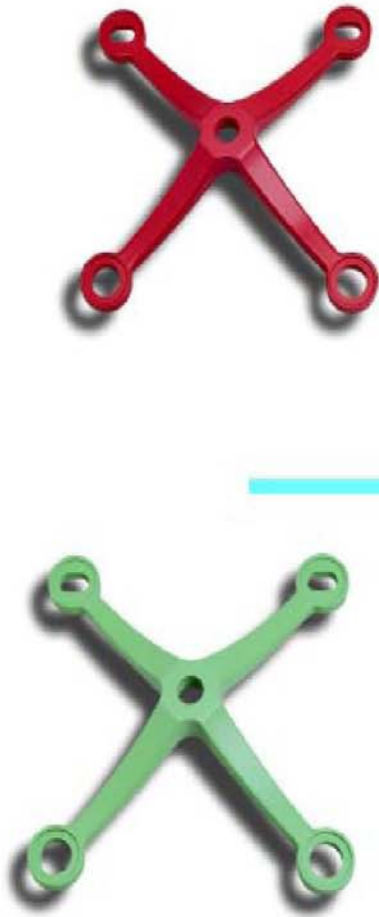

1): A wide varieties of color is available

2): Fluorocarbon coating finish has superior weathering and corrosion resistance characteristics hence, is recommended to use in heavily-polluted and/or marine environment.

Reference design load of spider (Material S.S. 316 and S.S.304)

No.	Spider name	Design axial load capability of single arm N* (Negative windload)	Design radial load capability of single arm N* (Dead load)
1	H130A	4000	1000
2	H160A	1500	1000
3	H160C	1500	1000
4	H160D	1500	1000
5	H160E	1500	1000
6	H200A	2000	1200
7	H200B	1500	1200
8	H200C	2000	1200
9	H210A	3000	1500
10	H220A	2800	1500
11	H220B	2200	1200
12	H220C	3500	2000
13	HS220D	3800	2000
14	H250A	3000	2000
15	H250BA	2500	2000
16	H250BB	2500	2000
17	H250BC	2000	1200
18	H250BD	4500	2000
19	H250BE	3500	1200
20	H250BF	2500	2000
21	H250C	3300	2000
22	H250D	4300	2000
23	H250E	3300	1200
24	H250F	2500	2000
25	H250G	3000	2000
26	H250H	4800	2000
27	H250R	3000	2000
28	H250K	4000	2000
29	H250L	3000	2000
30	H250M	5000	2500
31	HS250A	5000	2000
32	H300A	6000	2000
33	H300B	6300	2000
34	H300C	6000	2500

* Design values shown in the table are considered acceptable in China, and may not be adequate to fulfill acceptance criteria in other countries. For more stringent requirements, it is suggested to multiply the values in the table with a factor of 0.8. It would be even better for the designer user to test for adequacy against relevant national standard before use.

IN ARCHITECTURAL GLASS FITTINGS

No.	Spider name	Design axial load capability of single arm N* (Negative windload)	Design radial load capability of single arm N* (Dead load)
35	H300D	3000	2000
36	H300E	5000	2000
37	H300G	3500	1200
38	H2540A	6500	2000
39	H3040A	2500	1500
40	H3060A	3500	2000
41	H3060B	6500	2500
42	H3070A	6500	2500
43	H4706K	4000	2000
44	H4706G	4000	2000
45	H2542T	4000	2000
46	HJ3030T	5000	2000
47	H3535T	2500	1500
48	H3060T	3000	2000
49	HL210A	2000	1000
50	HL220A	4500	2000
51	HL220B	4500	2000
52	HL220C	4500	2000
53	HL250A	3800	2000
54	HL250B	4000	2000
55	HL250C	2200	1200
56	HL250D	4000	2000
57	HL250E	2300	1500
58	HL250F	3300	1500
59	HL250G	5000	2000
60	HL250H	4000	2000
61	HL265A	5500	2500
62	HL265B	5500	2500
63	HL300A	3500	----
64	HL300B	3500	1500
65	HL300C	3500	1500
66	HL300D	3500	1500
67	HL300E	3500	----
68	HL300F	3500	----

* Design values shown in the table are considered acceptable in China, and may not be adequate to fulfill acceptance criteria in other countries. For more stringent requirements, it is suggested to multiply the values in the table with a factor of 0.8. It would be even better for the designer user to test for adequacy against relevant national standard before use.

H120A Series



H120A (Previous Model: H1201A)



H120A21 (Previous Model: H1202A)

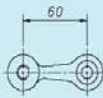
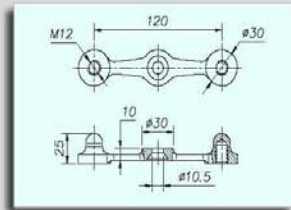
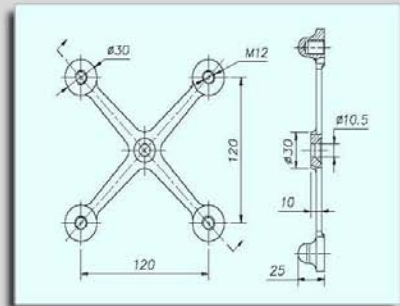

H120A12

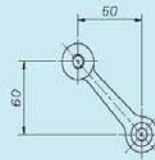

H120A13

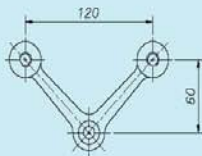

H120A23

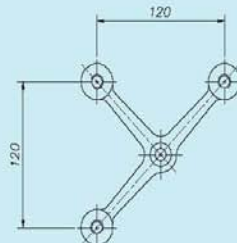

H120A31

IN ARCHITECTURAL GLASS FITTINGS

H130A Series



H130A (Previous Model: H1301)



H130A21 (Previous Model: H1302)

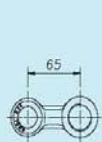
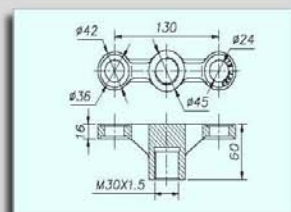
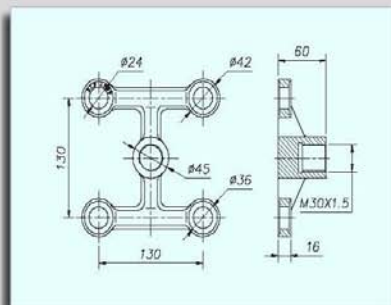

H130A11

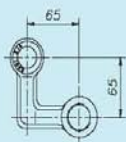

H130A13

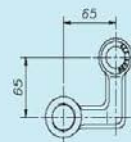

H130A14

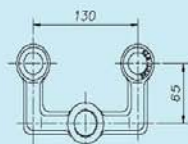

H130A23

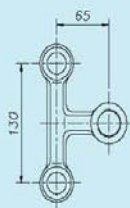

H130A25

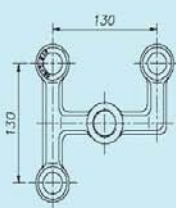

H130A31

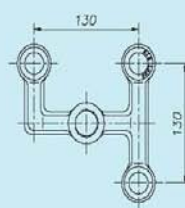

H130A32

H160A Series



H160A (Previous Model: H1601A)



H160A21 (Previous Model: H1602A)

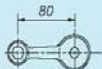
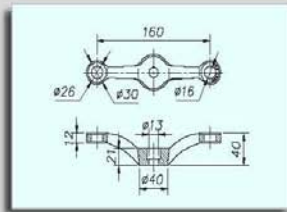
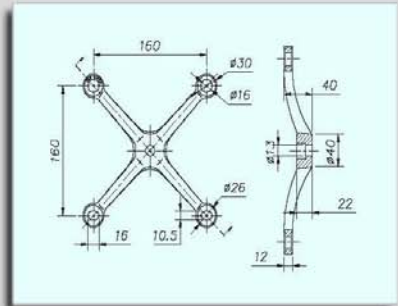

H160A11
Previous Model: H1604A

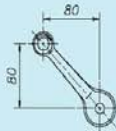

H160A13
Previous Model: H1605A

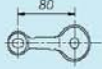

H160A12

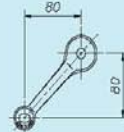

H160A15

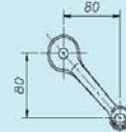

H160A16



H160A22

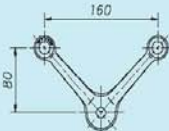

H160A23
Previous Model: H1603A



H160A27

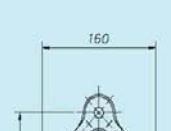

H160A24

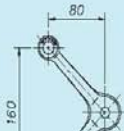

H160A25

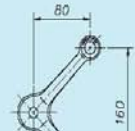

H160A26

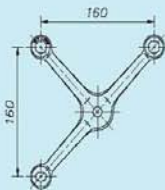

H160A31
Previous Model: H1606A

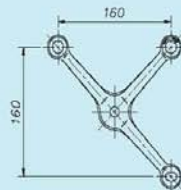

H160A32

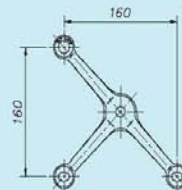

H160A33

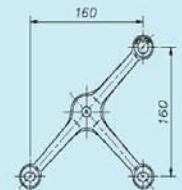

H160A34

IN ARCHITECTURAL GLASS FITTINGS

H160C Series



H160C (Previous Model: H1601C)



H160C21 (Previous Model: H1602C)

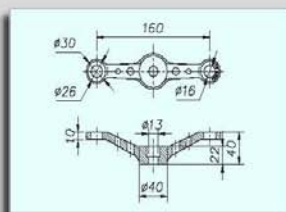
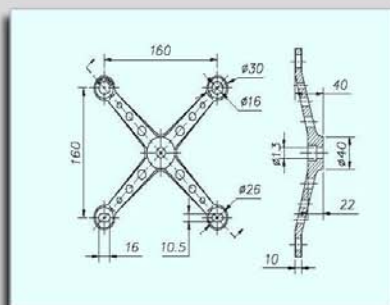

H160C11
Previous Model: H1604C



H160C12

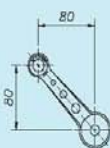

H160C13
Previous Model: H1605C

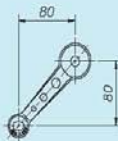

H160C15

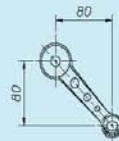

H160C16

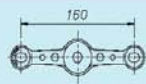

H160C22

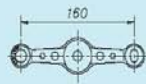

H160C27

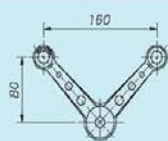

H160C23
Previous Model: 1603CH

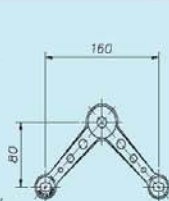

H160C24

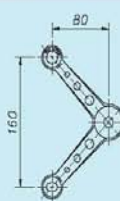

H160C25

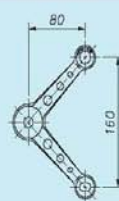

H160C26

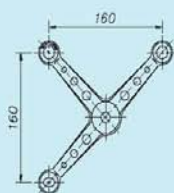

H160C31
Previous Model: H1606C

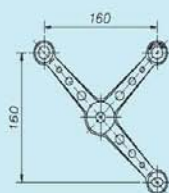

H160C32

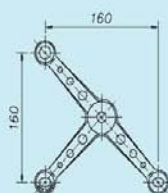

H160C33

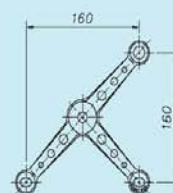

H160C34

H160D Series



H160D (Previous Model: H1601D)



H160D21 (Previous Model: H1602D)

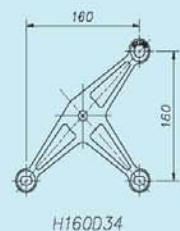
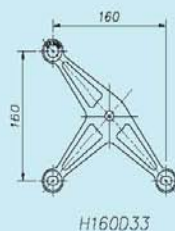
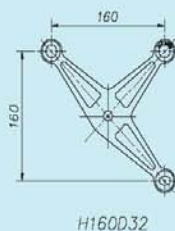
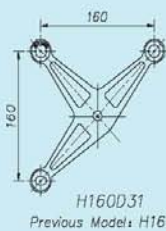
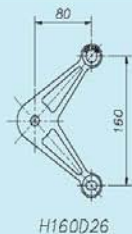
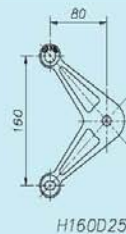
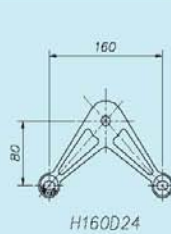
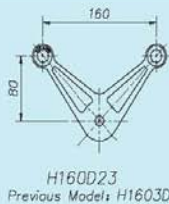
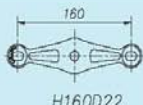
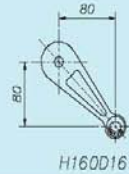
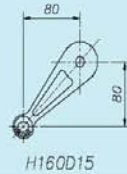
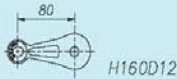
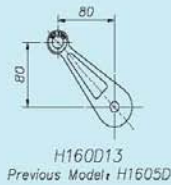
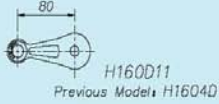
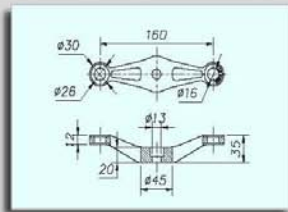
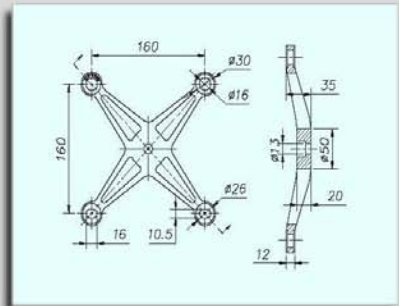

IN ARCHITECTURAL GLASS FITTINGS

H160E Series



H160E (Previous Model: H1601E)



H160E21 (Previous Model: H1602E)

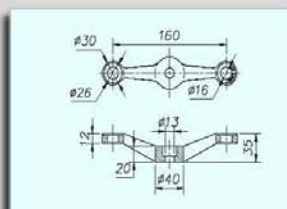
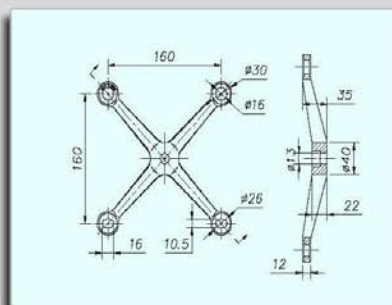

H160E11
Previous Model: H1604E

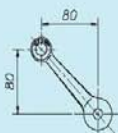

H160E13
Previous Model: H1605E



H160E12

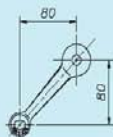

H160E15



H160E16



H160E22

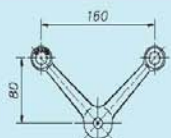

H160E23
Previous Model: H1603E

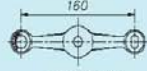

H160E27

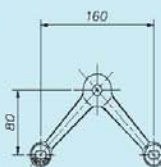

H160E24

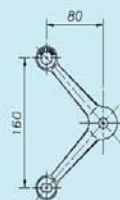

H160E25

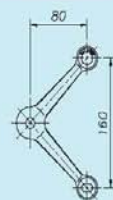

H160E26

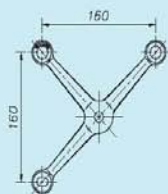

H160E31
Previous Model: H1606E

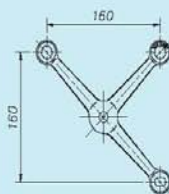

H160E32

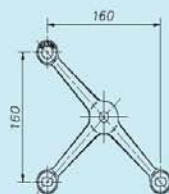

H160E33

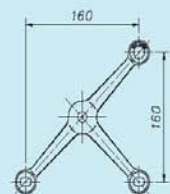

H160E34

H200A Series



H200A (Previous Model: H2001A)



H200A21 (Previous Model: H2002A)

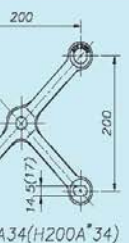
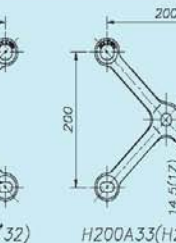
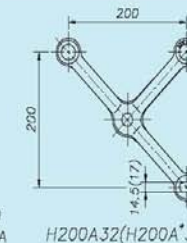
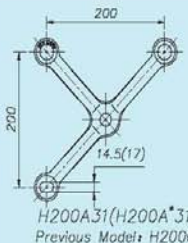
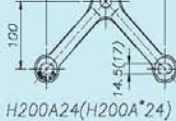
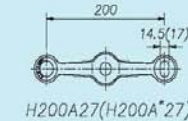
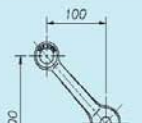
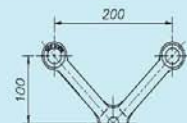
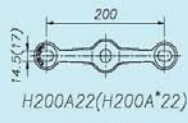
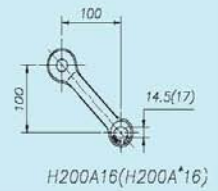
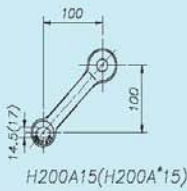
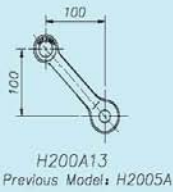
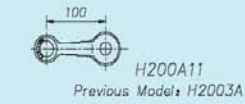
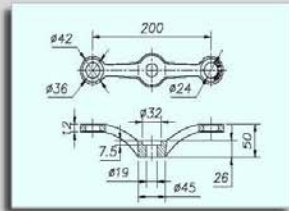
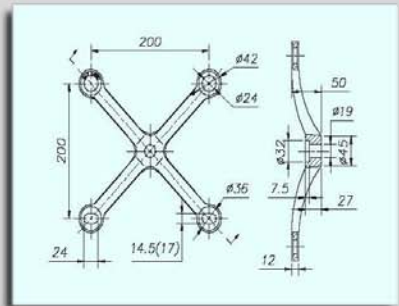

IN ARCHITECTURAL GLASS FITTINGS

H200B Series



H200B (Previous Model: H2001B)



H200B21 (Previous Model: H2002B)

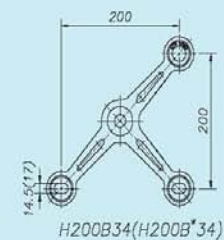
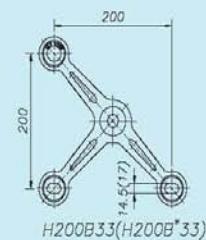
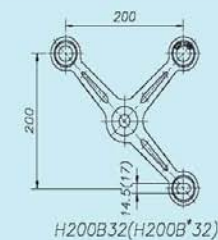
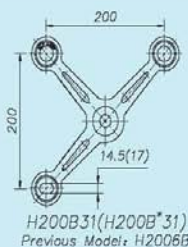
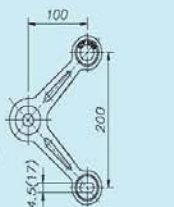
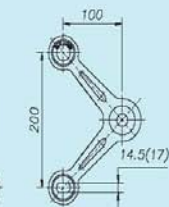
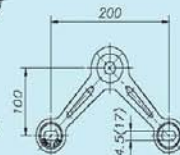
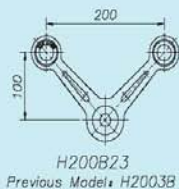
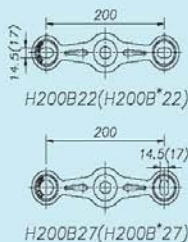
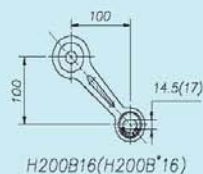
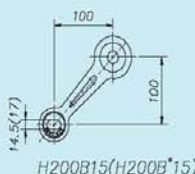
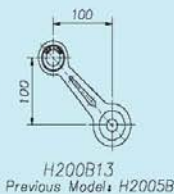
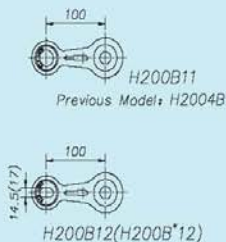
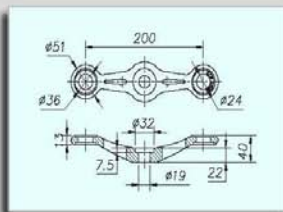
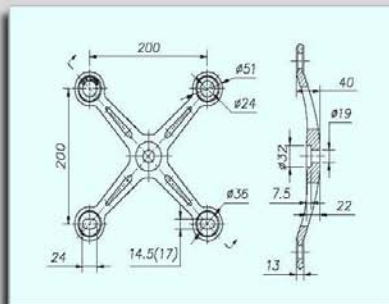

H200C Series



H200C (Previous Model: H2001C)



H200CA21 (Previous Model: H2002C)

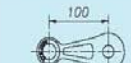
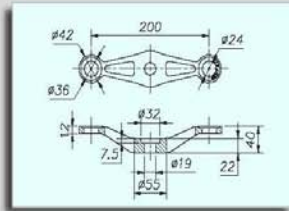
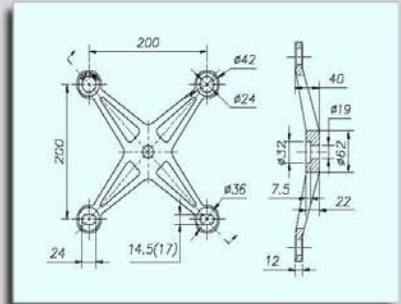

H200C11

Previous Model: H2004C

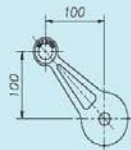

H200C13

Previous Model: H2005C

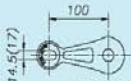

H200C12(H200C*12)

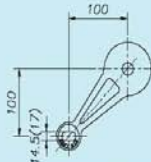

H200C15(H200C*15)

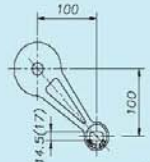

H200C16(H200C*16)



H200C22(H200C*22)



H200C23

Previous Model: H2003C



H200C24(H200C*24)



H200C25(H200C*25)

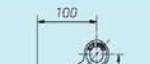

H200C26(H200C*26)



H200C27(H200C*27)

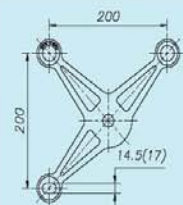

H200C31(H200C*31)
Previous Model: H2006C

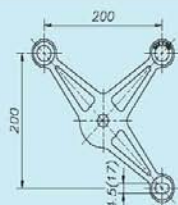

H200C32(H200C*32)

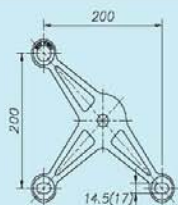

H200C33(H200C*33)

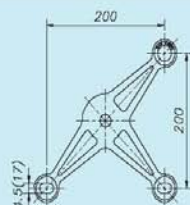

H200C34(H200C*34)

IN ARCHITECTURAL GLASS FITTINGS

H210A Series

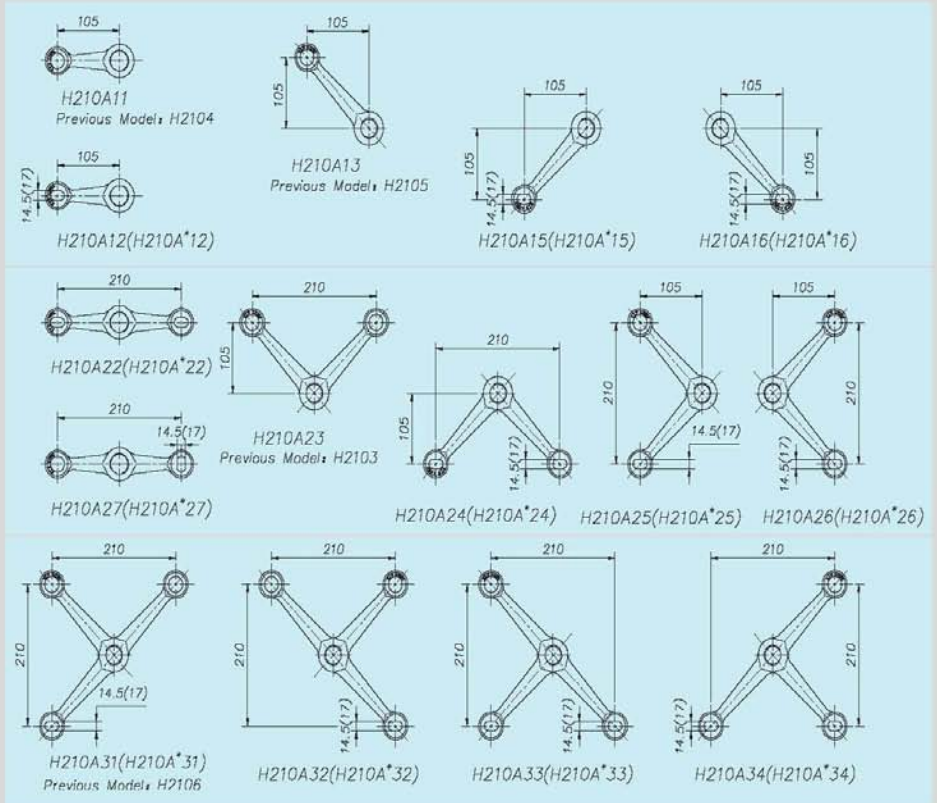
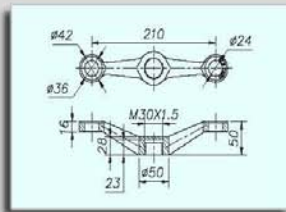
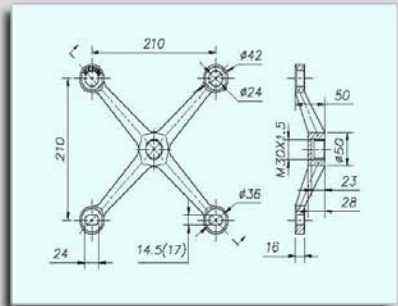

H220A Series



H220A (Previous Model: H2201E)



H220A21 (Previous Model: H2202E)

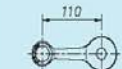
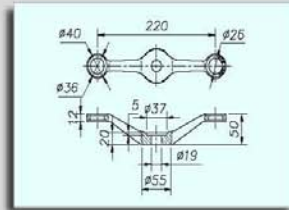
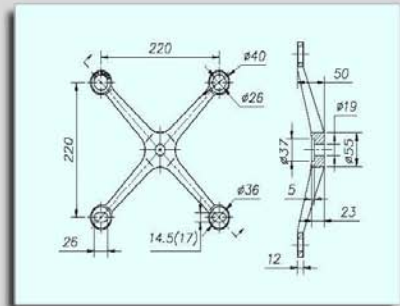

H220A11
Previous Model: H2204E

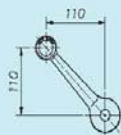

220A13
Previous Model: H2205E

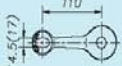

H220A12(H220A*12)

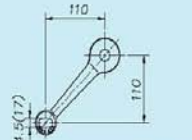

H220A15(H220A*15)

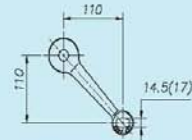

H220A16(H220A*16)



H220A22(H220A*22)

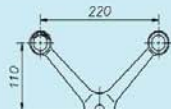

H220A23
Previous Model: H2203E

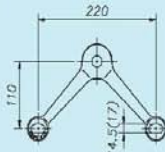

H220A24(H220A*24)

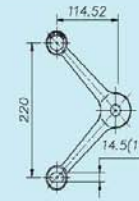

H220A25(H220A*25)

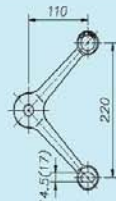

H220A26(H220A*26)

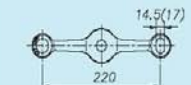

H220A27(H220A*27)

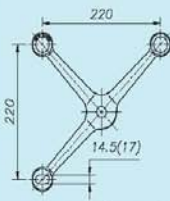

H220A31(H220A*31)
Previous Model: H2206F

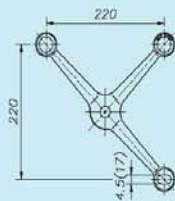

H220A32(H220A*32)

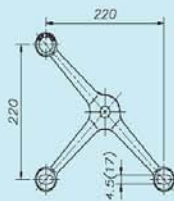

H220A33(H220A*33)

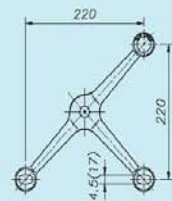

H220A34(H220A*34)

IN ARCHITECTURAL GLASS FITTINGS

H220B Series



H220B (Previous Model: H2201B)

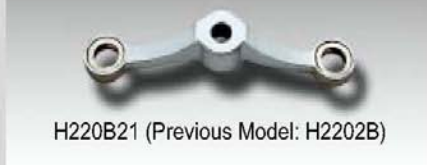

H220B21 (Previous Model: H2202B)

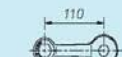
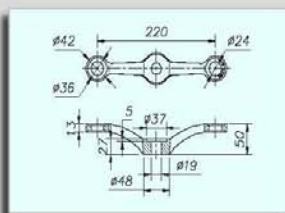
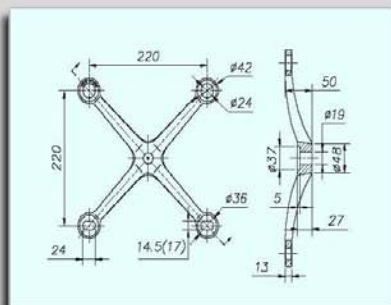

H220B11
Previous Model: H2204B

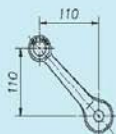

H220B13
Previous Model: H2205B

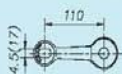

H220B12(H220B*12)

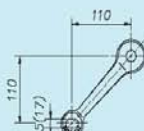

H220B15(H220B*15)

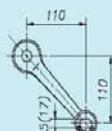

H220B16(H220B*16)

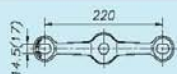

H220B22(H220B*22)

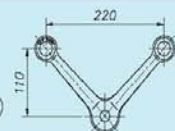

H220B23
Previous Model: H2203B

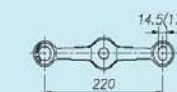

H220B27(H220B*27)

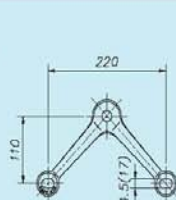

H220B24(H220B*24)

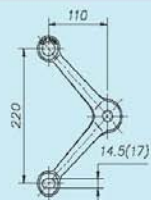

H220B25(H220B*25)

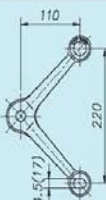

H220B26(H220B*26)

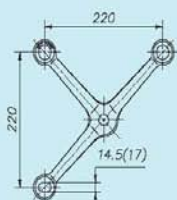

H220B31(H220B*31)
Previous Model: H2206B

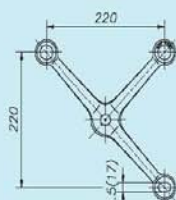

H220B32(H220B*32)

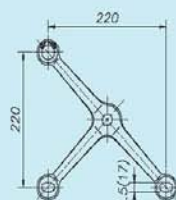

H220B33(H220B*33)

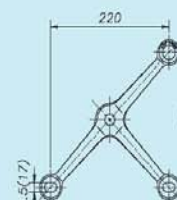

H220B34(H220B*34)

H220C Series



H220C (Previous Model: H2207)



H220C21 (Previous Model: H2202)

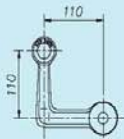
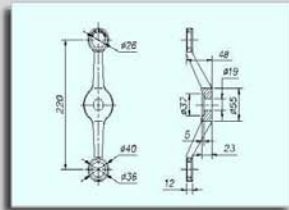
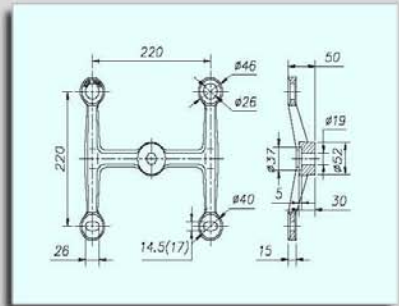

H220C13

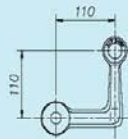

H220C14

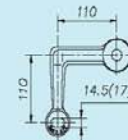

H220C15(H220C*15)

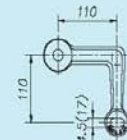

H220C16(H220C*16)

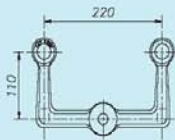

H220C23

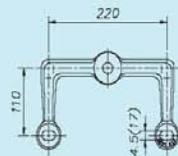

H220C24(H220C*24)

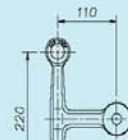

H220C25(H220C*25)

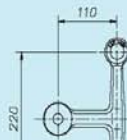

H220C26(H220C*26)

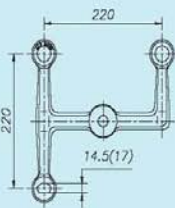

H220C31(H220C*31)

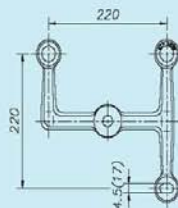

H220C32(H220C*32)

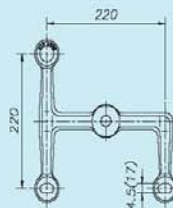

H220C33(H220C*33)

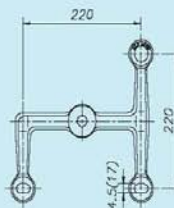

H220C34(H220C*34)

IN ARCHITECTURAL GLASS FITTINGS

HS220A Series

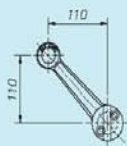
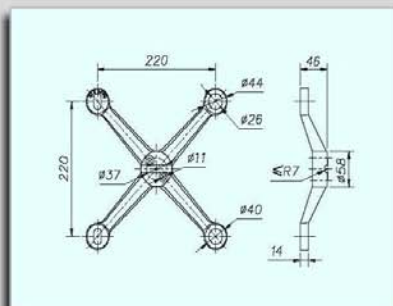

HS220A13

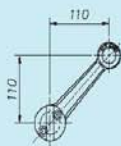

HS220A14

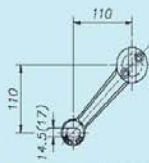

HS220A15(HS220A*15)

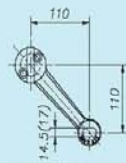

HS220A16(HS220A*16)

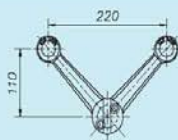

HS220A23

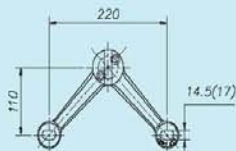

HS220A24(HS220A*24)

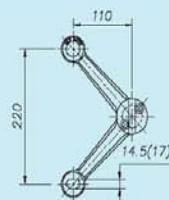

HS220A25(HS220A*25)

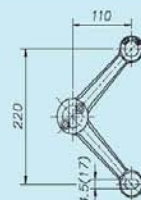

HS220A26(HS220A*26)

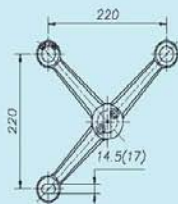

HS220A31(HS220A*31)

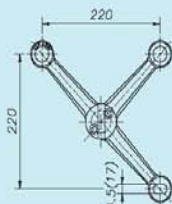

HS220A32(HS220A*32)

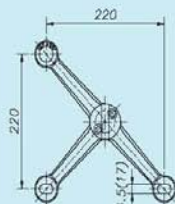

HS220A33(HS220A*33)

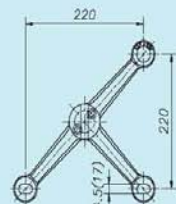

HS220A34(HS220A*34)



H250A



H220C



H250D



H250A11



H250A12



H250A13



H250A21



H250A22



H250A23



H250A24



H250A31



H250A32



H250A33

H250A Series



H250A (Previous Model: H2501T)

H250A21 (Previous Model: H2502T)

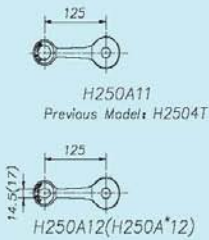
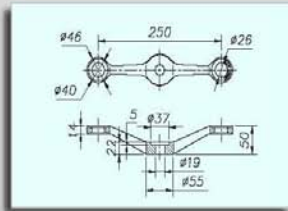
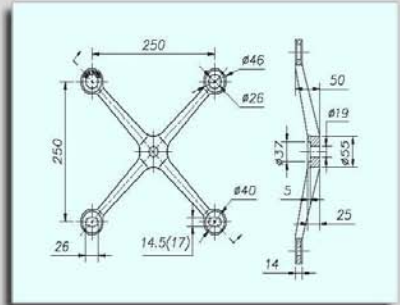

H250A11

Previous Models: H2504T



H250A12(H250A*12)

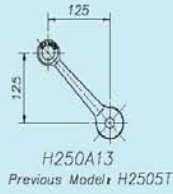

H250A13

Previous Models: H2505T

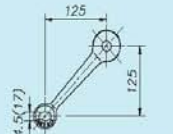

H250A15(H250A*15)

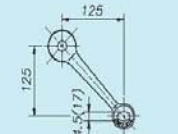

H250A16(H250SA*16)

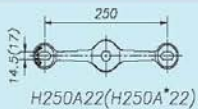

H250A22(H250A*22)

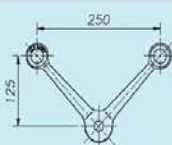

H250A23

Previous Models: H2503T

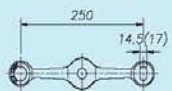

H250A27(H250A*27)

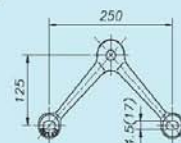

H250A24(H250A*24)

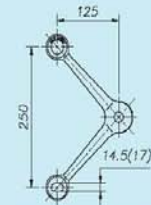

H250A25(H250A*25)

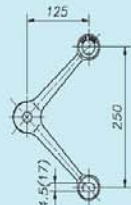

H250A26(H250A*26)

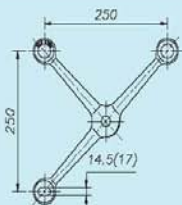

H250A31(H250A*31)

Previous Model: H2506T

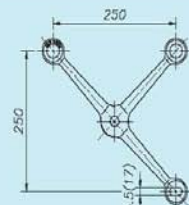

H250A32(H250A*32)

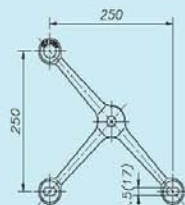

H250A33(H250A*33)

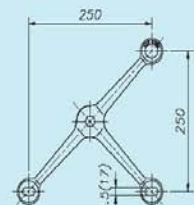

H250A34(H250A*34)

IN ARCHITECTURAL GLASS FITTINGS

H250AA Series

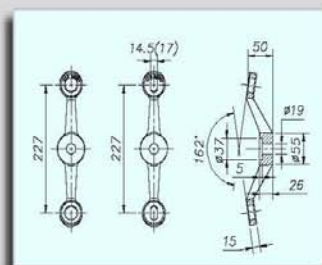
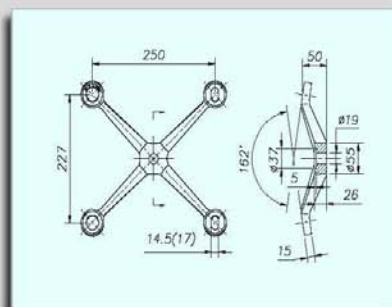

H250AB Series

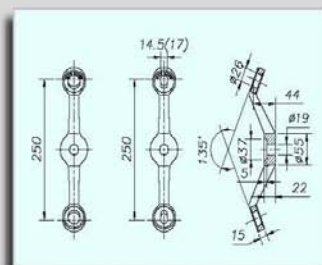
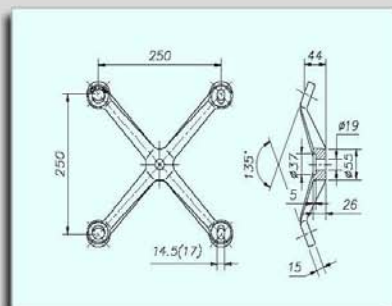
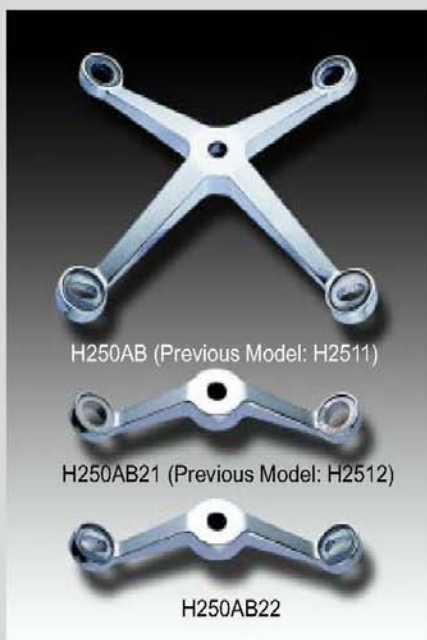

H250AC Series

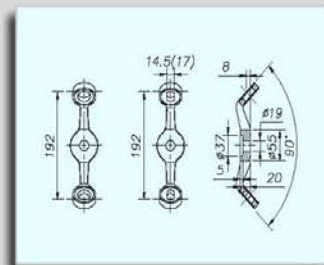
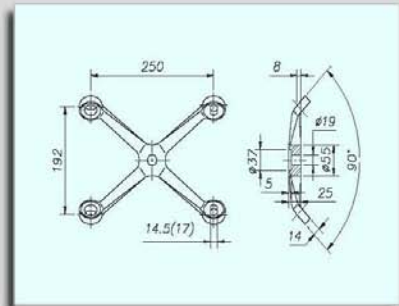

H250AD Series

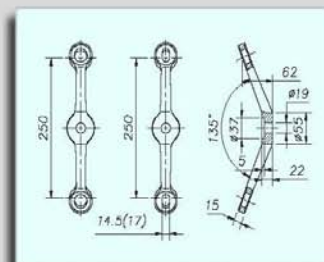
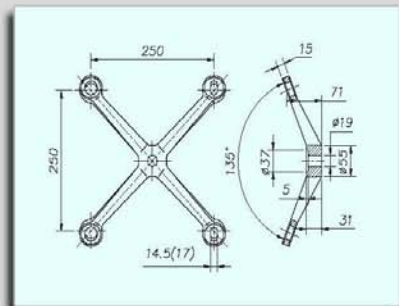

IN ARCHITECTURAL GLASS FITTINGS

H250AE Series



H250AE (Previous Model: H2515)



H250AE21 (Previous Model: H2516)



H250AE22



H250AE23



H250AE24

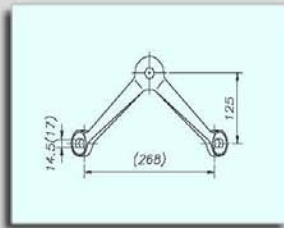
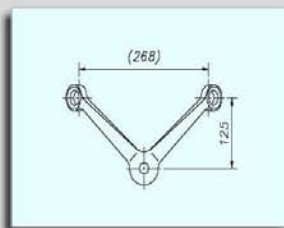
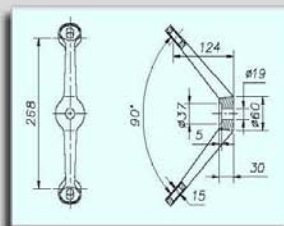
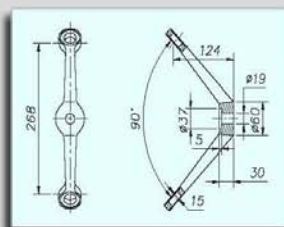
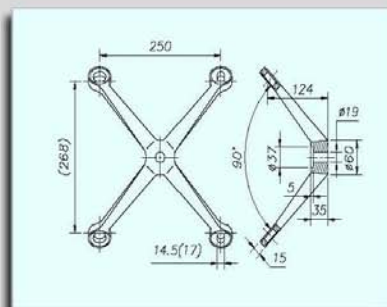

H250BA Series



H250BA (Previous Model: H2501B)



H250BA21 (Previous Model: H2502B)

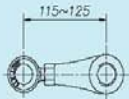
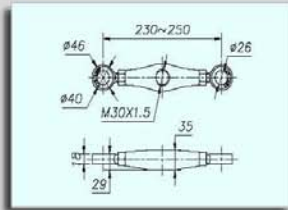
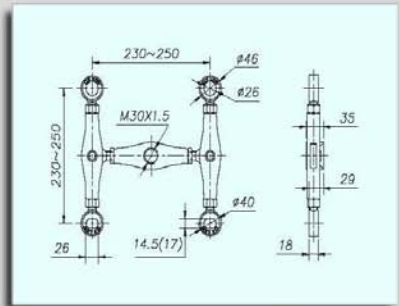

H250BA11
Previous Model: H2503B

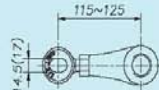

H250BA12(H250BA*12)

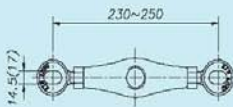

H250BA22(H250BA*22)

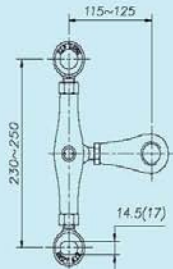

H250BA25(H250BA*25)

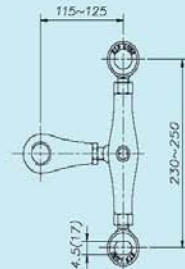

H250BA26(H250BA*26)

IN ARCHITECTURAL GLASS FITTINGS

H250BB Series

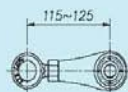
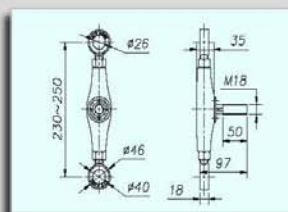
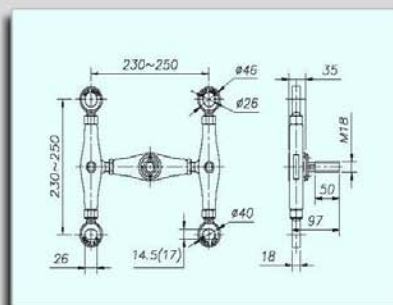

H250BB11

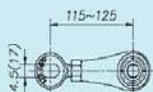

H250BB12(H250BB*12)



H250BB22(H250BB*22)

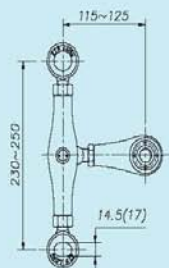

H250BB25(H250BB*25)

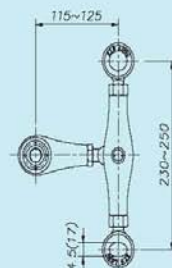

H250BB26(H250BB*26)

H250BC Series



H250BC (Previous Model: H250BF)

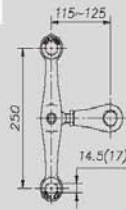
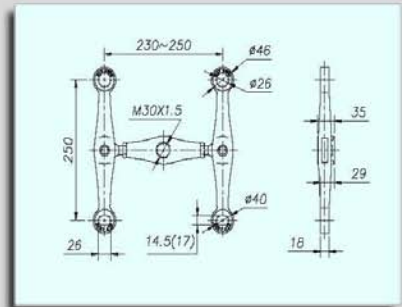

H250BC25(H250BC*25)

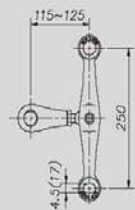

H250BC26(H250BC*26)

H250BD Series



H250BD (Previous Model: H2505B)

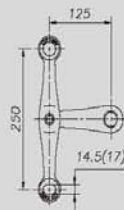
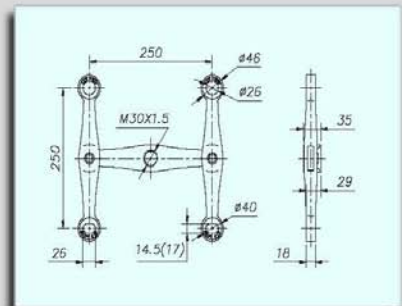

H250BD25(H250BD*25)

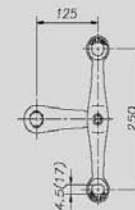

H250BD26(H250BD*26)

IN ARCHITECTURAL GLASS FITTINGS

H250BE Series



H250BE (Previous Model: H2506B)



H250BE21 (Previous Model: H2507B)

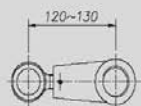
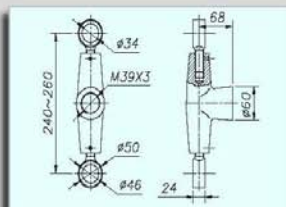
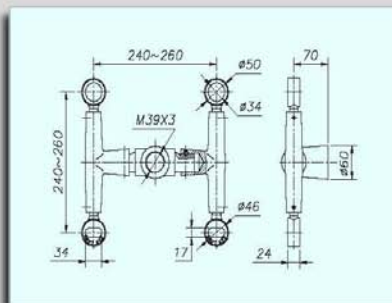

H250BE11

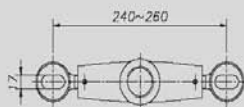

H250BE22

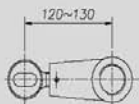

H250BE12

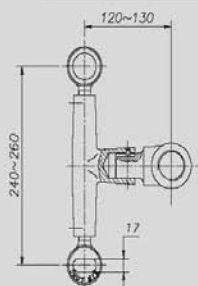

H250BE25

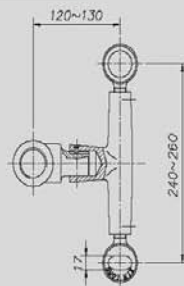

H250BE26

H250BF Series



H250BF (Previous Model: HW2501)

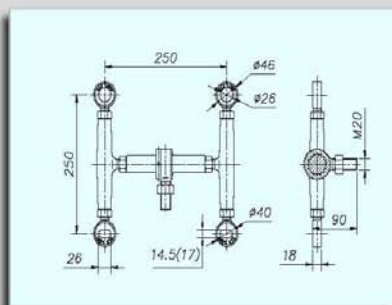

H250C Series



H250C (Previous Model: H2501C)



H250C21 (Previous Model: H2502C)

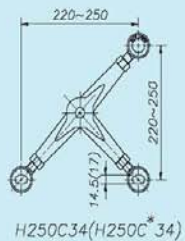
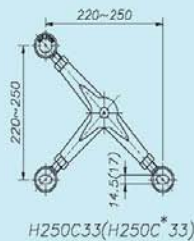
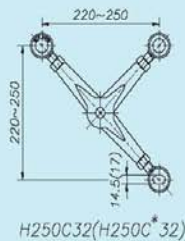
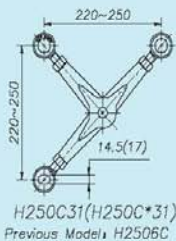
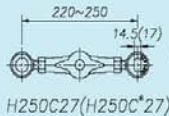
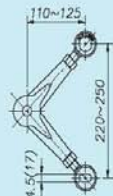
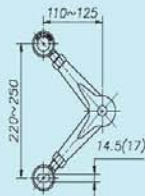
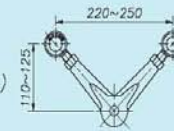
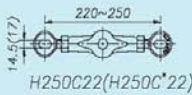
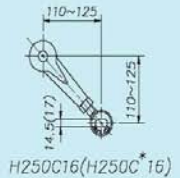
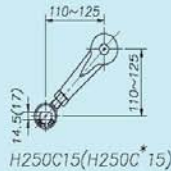
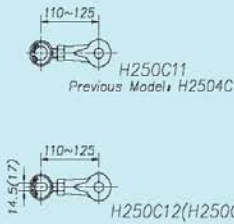
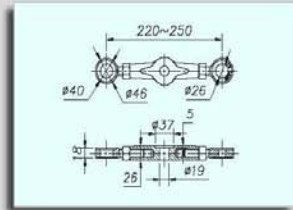
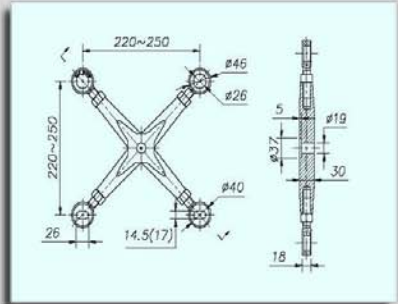

IN ARCHITECTURAL GLASS FITTINGS

H250D Series



H250D (Previous Model: H2501D)



H250D23 (Previous Model: H2502D)



H250D31 (Previous Model: H2505D)



H250D32 (Previous Model: H2506D)

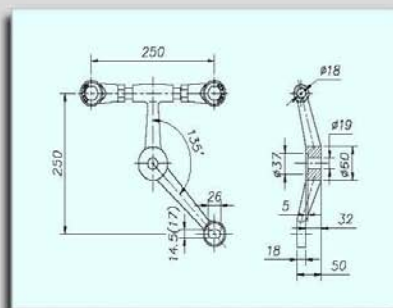
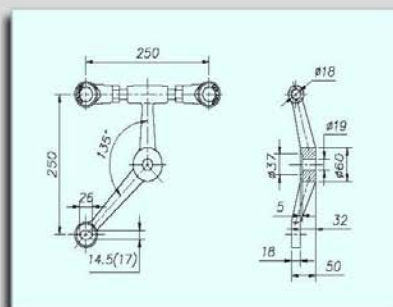
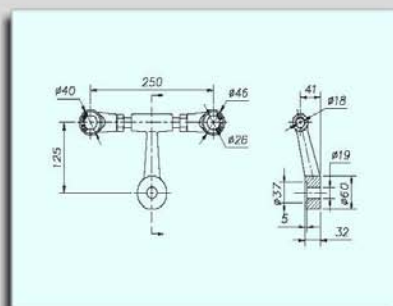
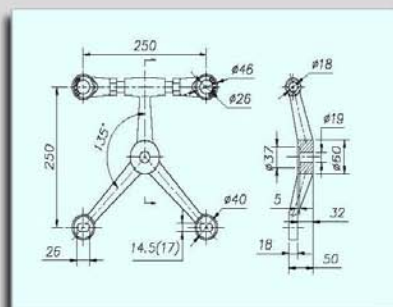

H250E Series

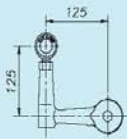
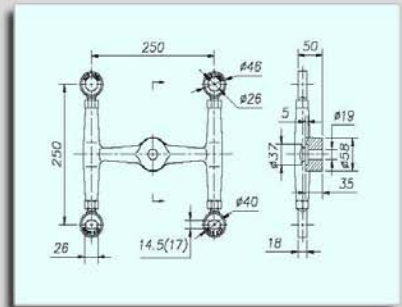

H250E13

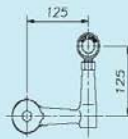

H250E14

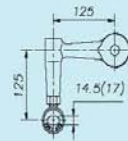

H250E15(H250E*15)

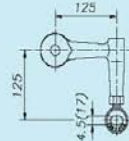

H250E16(H250E*16)

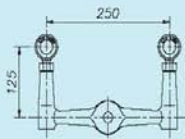

H250E23

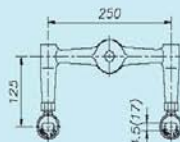

H250E24(H250E*24)

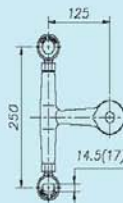

H250E25(H250E*25)

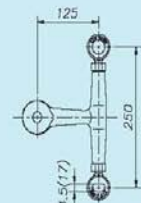

H250E26(H250E*26)

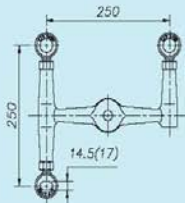

H250E31(H250E*31)

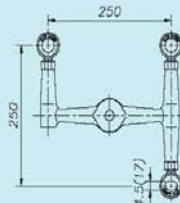

H250E32(H250E*32)

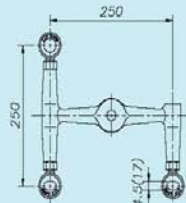

H250E33(H250E*33)

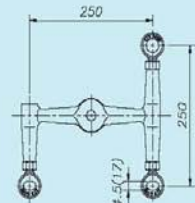

H250E34(H250E*34)

IN ARCHITECTURAL GLASS FITTINGS

H250F Series

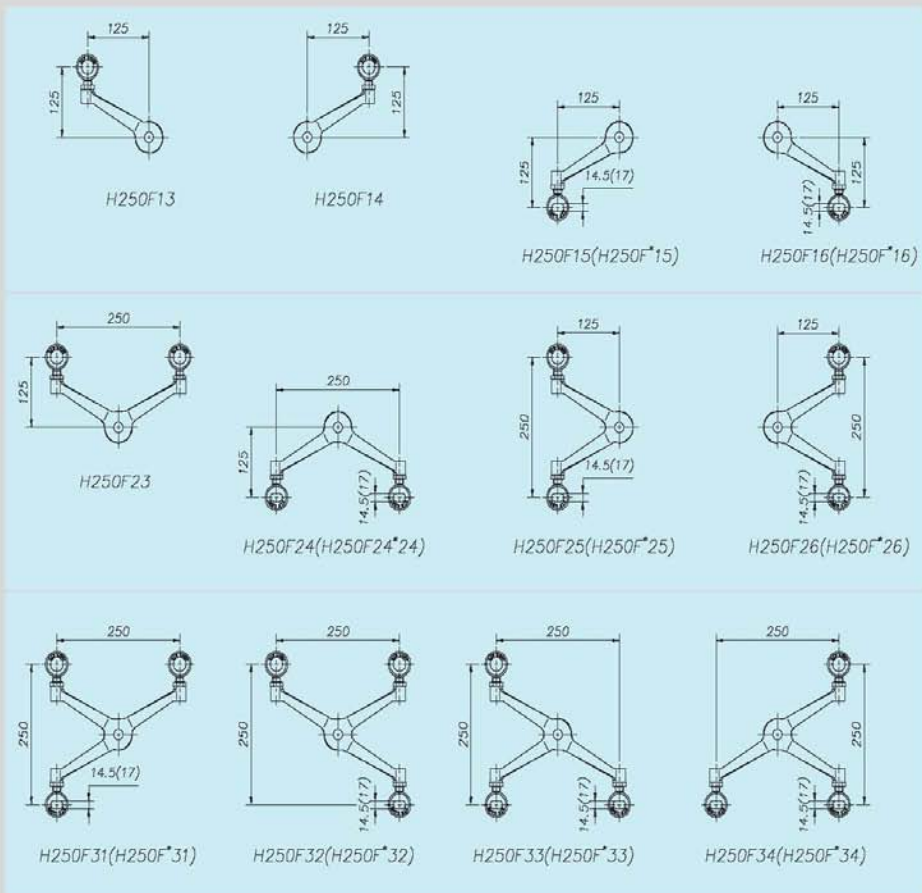
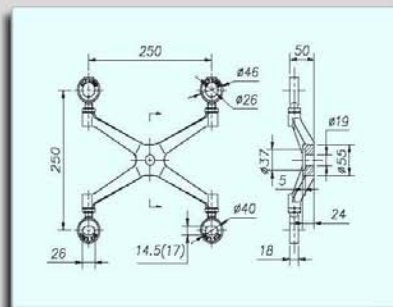

H250G Series

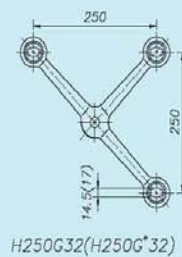
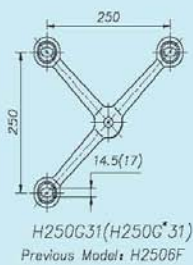
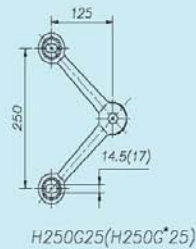
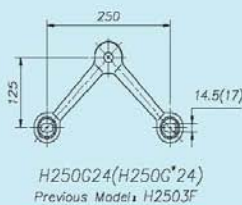
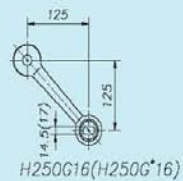
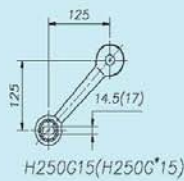
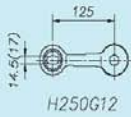
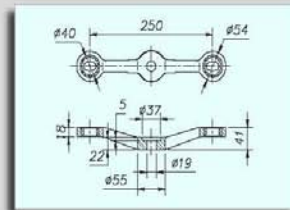
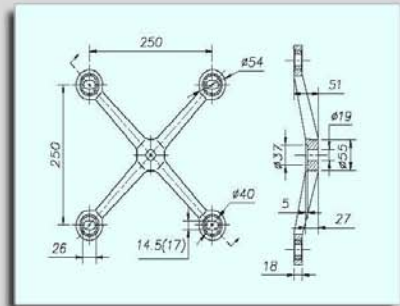

IN ARCHITECTURAL GLASS FITTINGS

H250H Series



H250H (Previous Model: H2501H)



H250H21 (Previous Model: H2502H)

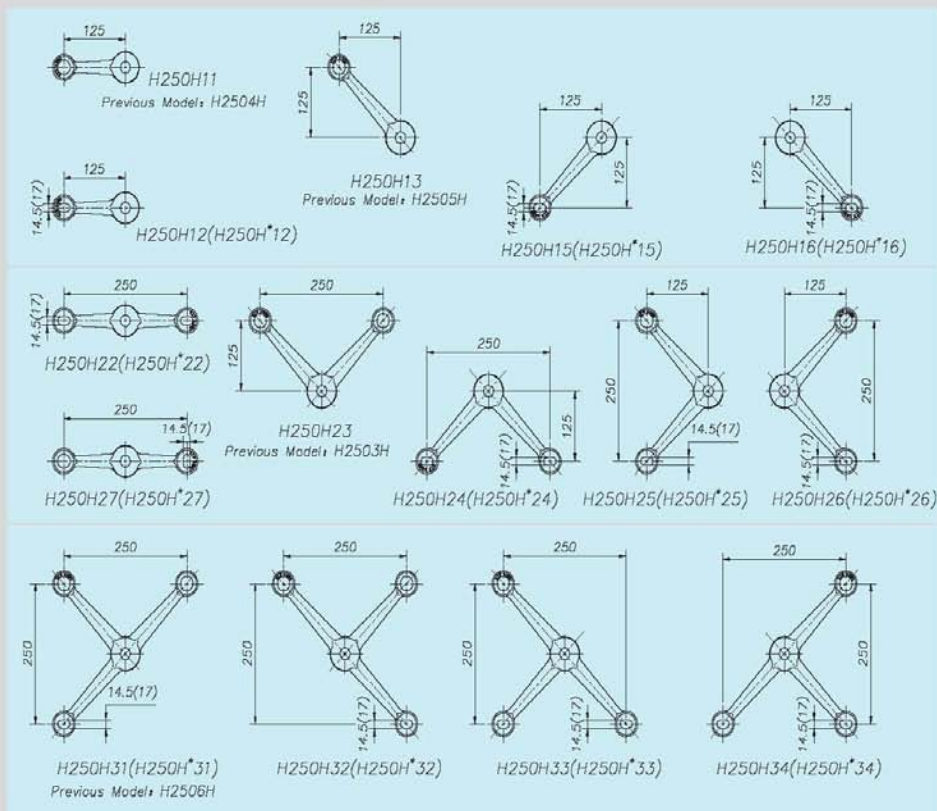
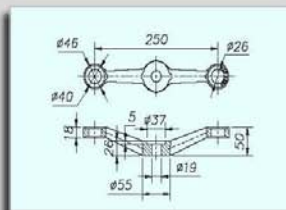
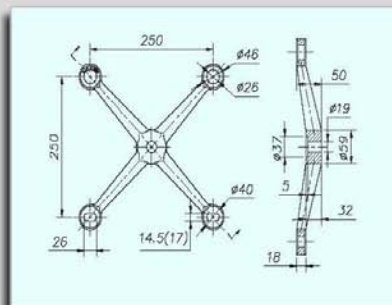

H250K Series



H250K (Previous Model: H2501K)



H250K21 (Previous Model: H2502K)

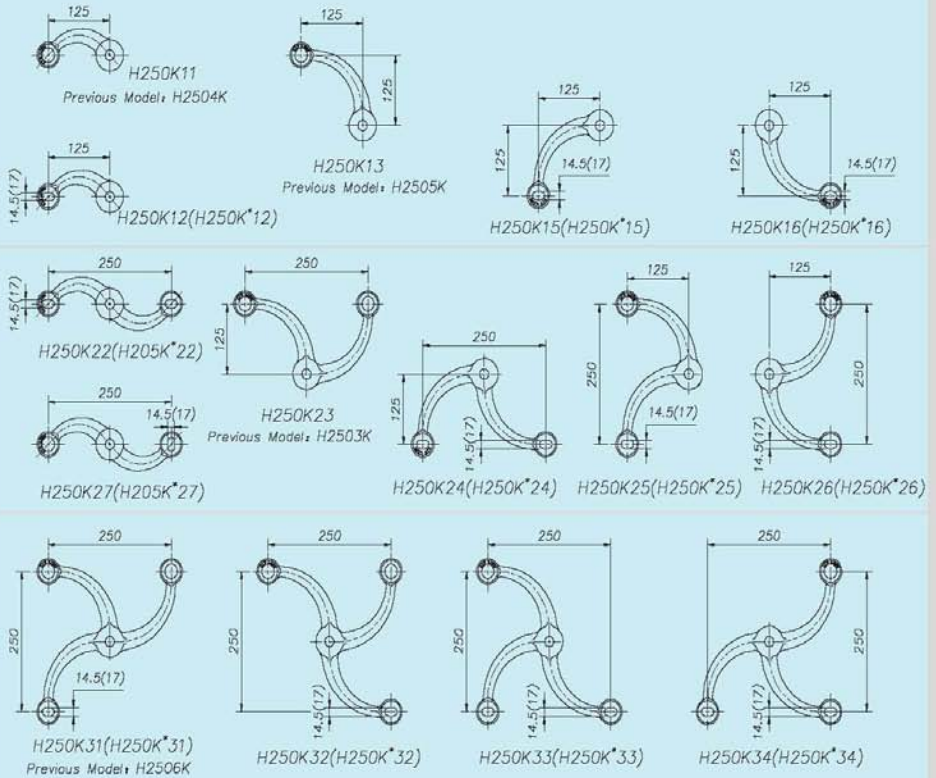
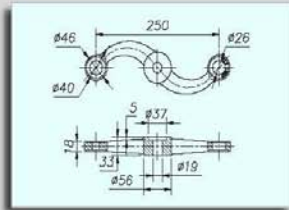
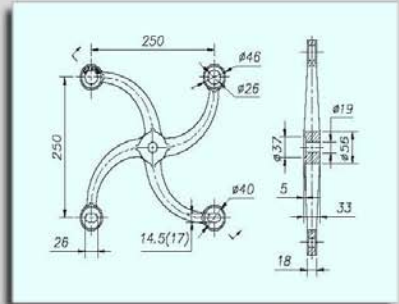

IN ARCHITECTURAL GLASS FITTINGS

H250L Series

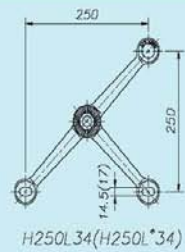
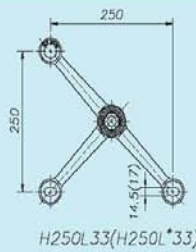
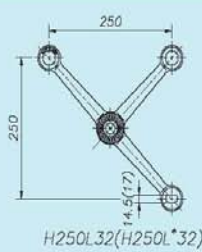
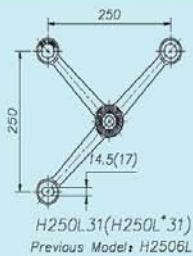
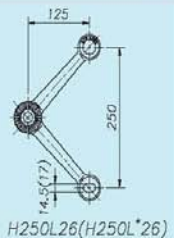
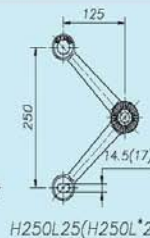
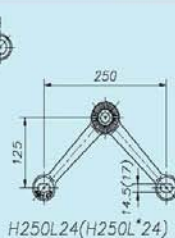
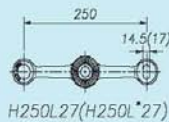
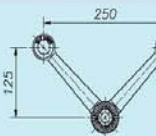
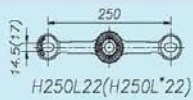
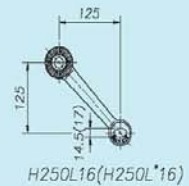
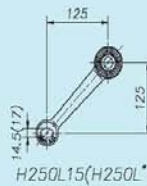
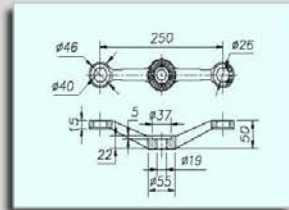
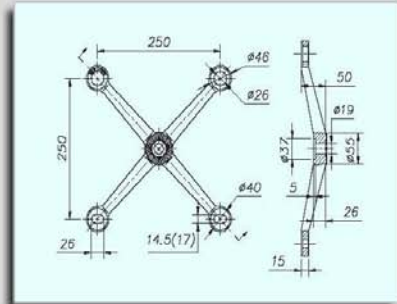

H250R Series

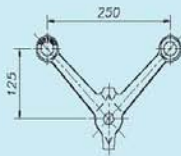
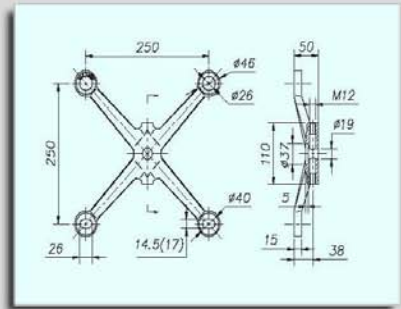

H250R23

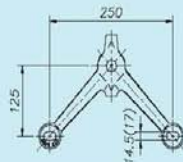

H250R24(H250R*24)

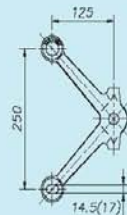

H250R25(H250R*25)

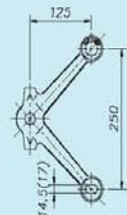

H250R26(H250R*26)

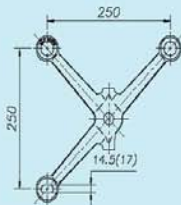

H250R31(H250R*31)

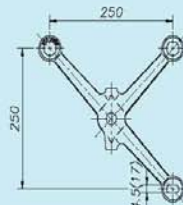

H250R32(H250R*32)

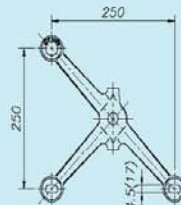

H250R33(H250R*33)

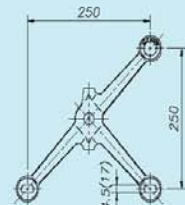

H250R34(H250R*34)

IN ARCHITECTURAL GLASS FITTINGS

HS250A Series

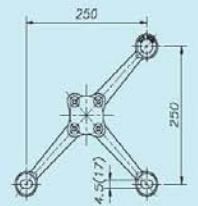
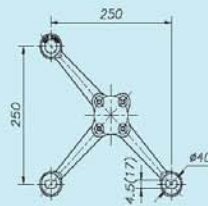
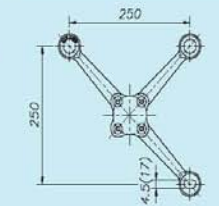
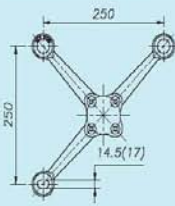
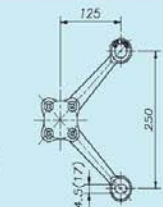
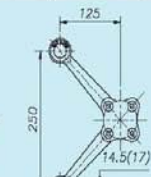
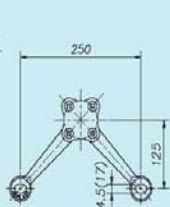
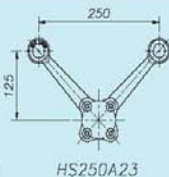
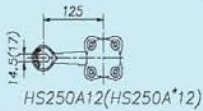
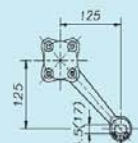
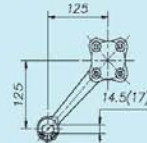
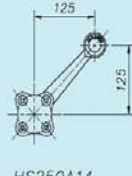
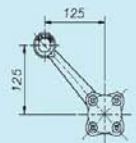
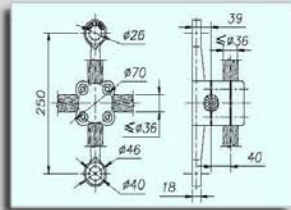
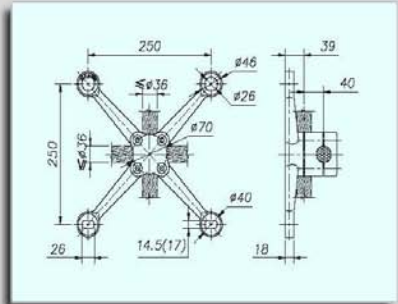

H300A Series



H300A (Previous Model: H3001)

H300A21 (Previous Model: H3002)

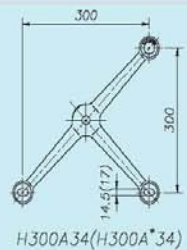
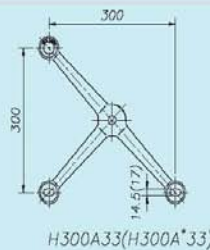
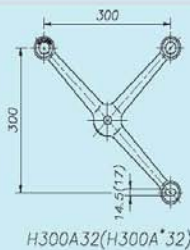
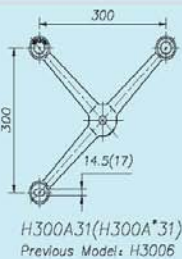
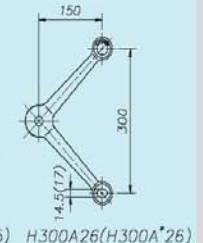
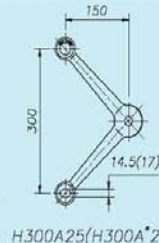
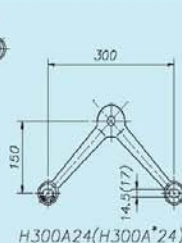
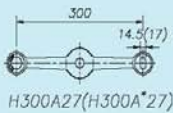
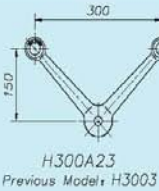
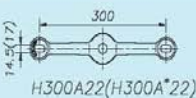
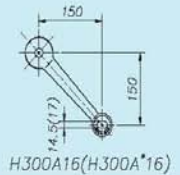
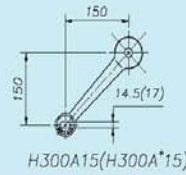
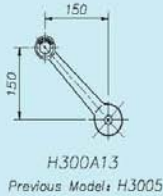
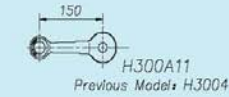
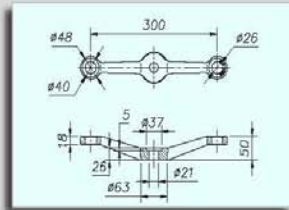
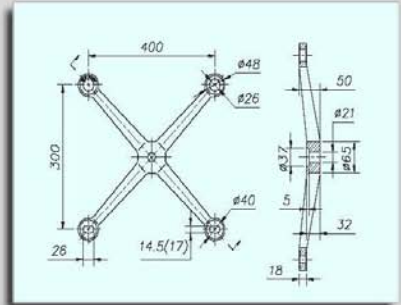

IN ARCHITECTURAL GLASS FITTINGS

H300B Series



H300B (Previous Model: H3001B)

H300B21 (Previous Model: H3002B)

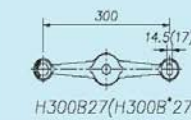
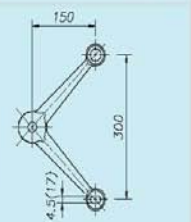
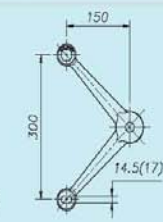
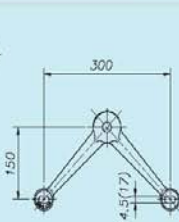
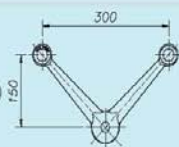
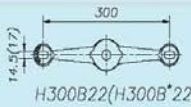
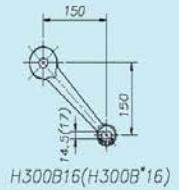
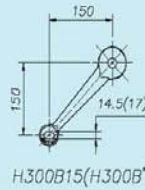
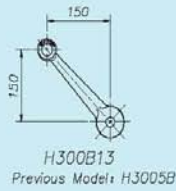
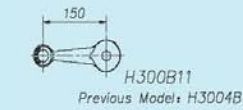
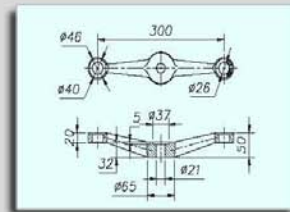
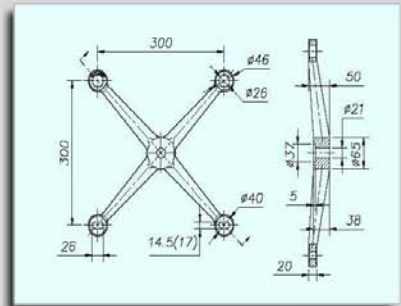

H300B24(H300B*24)

H300B25(H300B*25)

H300B26(H300B*26)

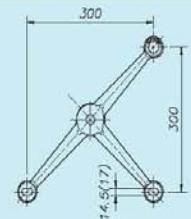
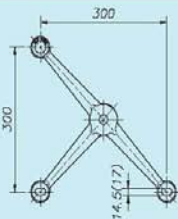
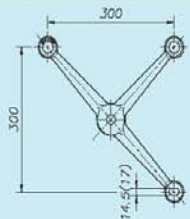
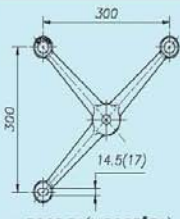

H300B31(H300B*31)
Previous Model: H3006B

H300B32(H300B*32)

H300B33(H300B*33)

H300B34(H300B*34)

H300C Series



H300C (Previous Model: H3001C)



H300C21 (Previous Model: H3002C)

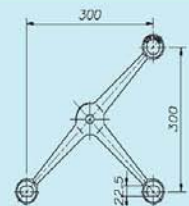
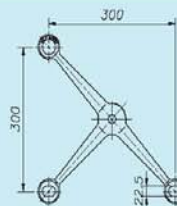
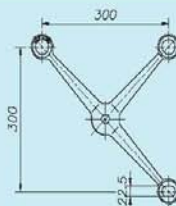
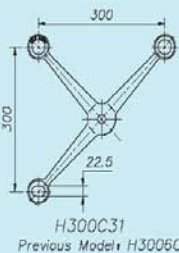
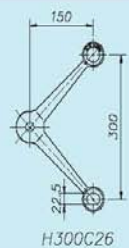
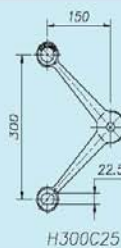
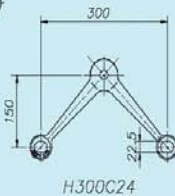
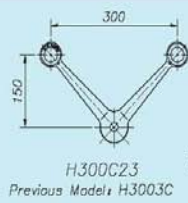
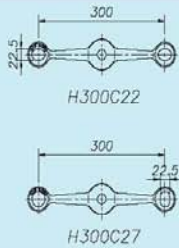
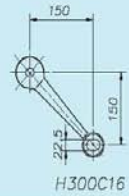
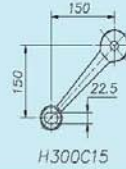
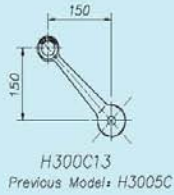
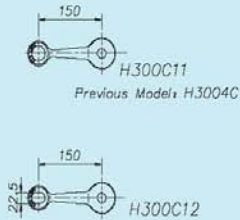
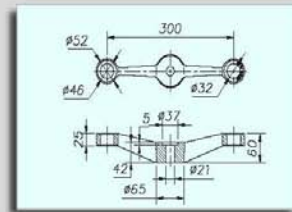
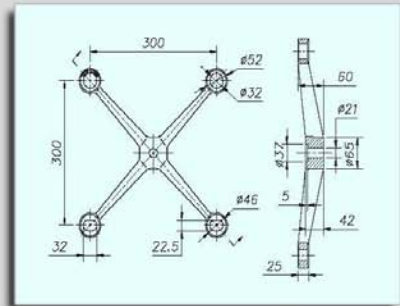

IN ARCHITECTURAL GLASS FITTINGS

H300D Series

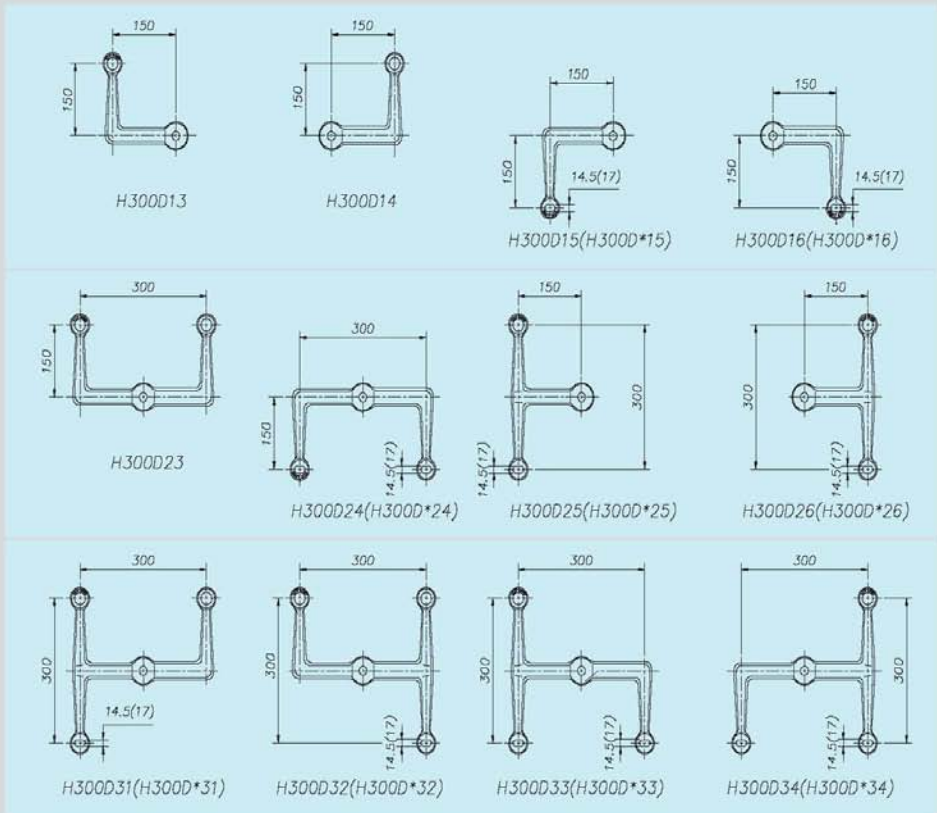
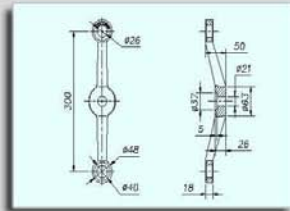
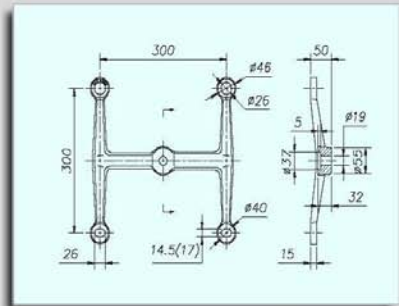

H300E Series

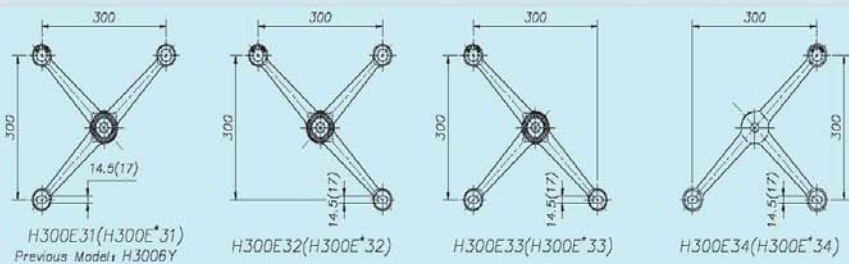
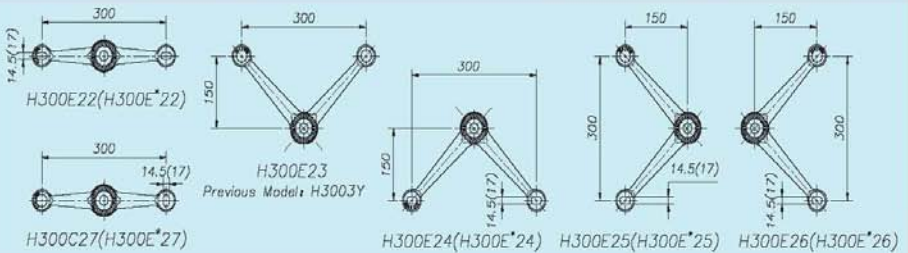
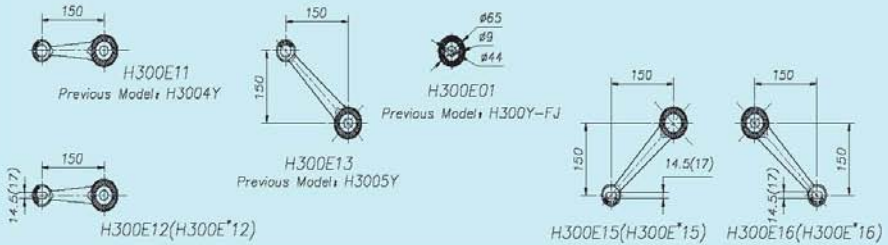
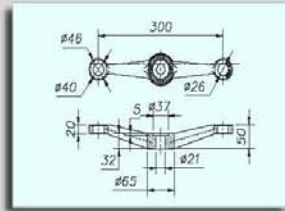
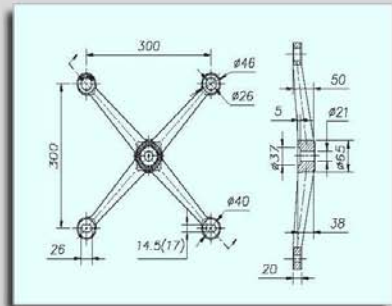

IN ARCHITECTURAL GLASS FITTINGS

H300G Series



H300G (Previous Model: H3001A)



H300G23 (Previous Model: H3002A)



H300G01 (Previous Model: H3003A)

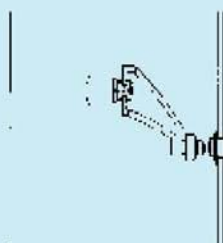
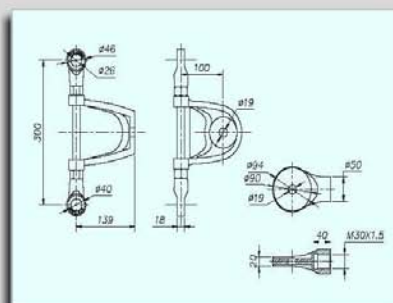
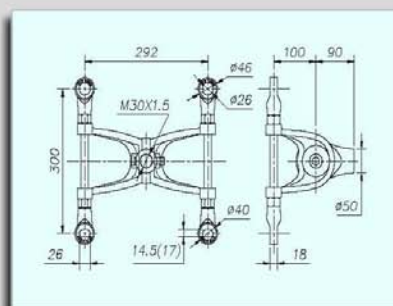

Spider
Moder:H300G23



Connector



IN ARCHITECTURAL GLASS FITTINGS

H3040A Series

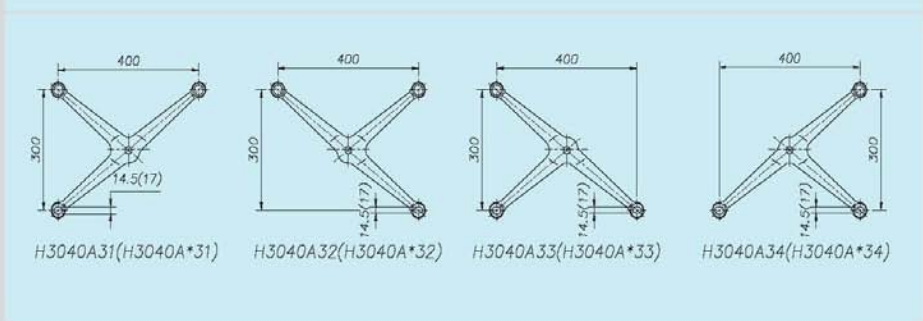
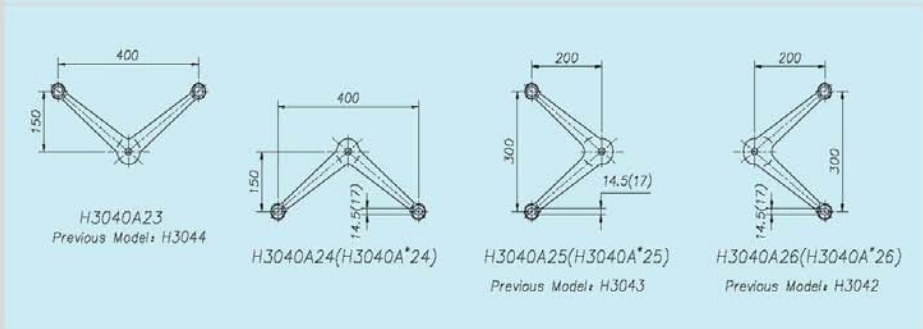
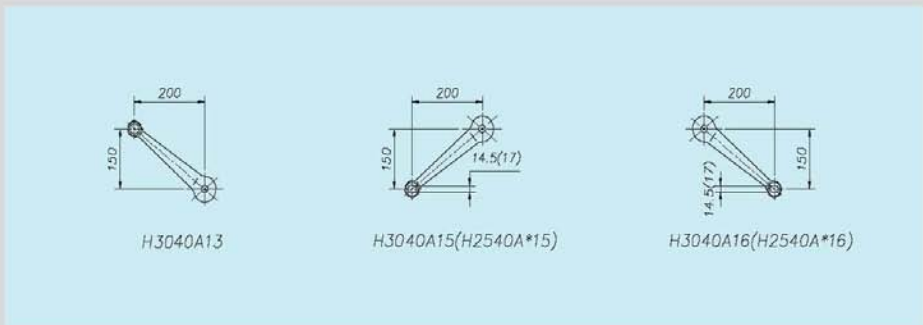
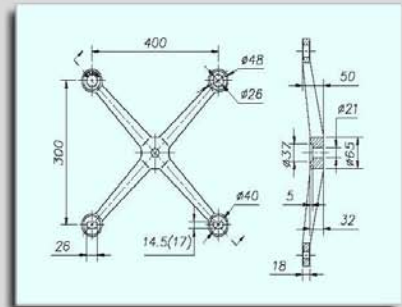

H3060A Series

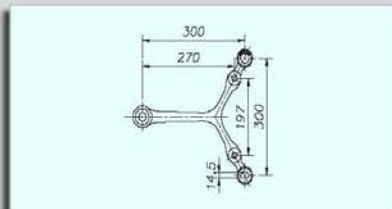
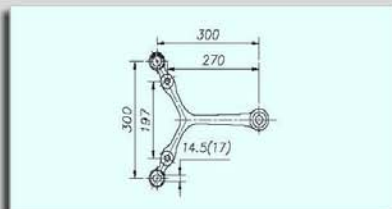
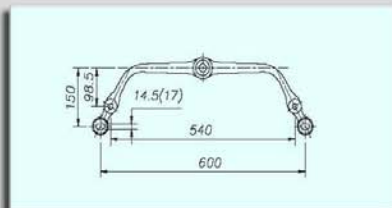
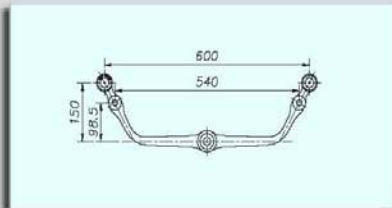
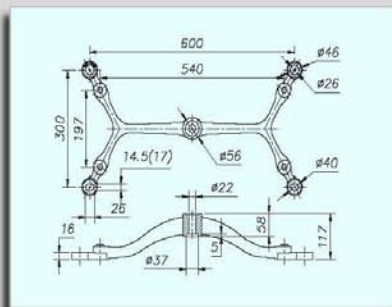

IN ARCHITECTURAL GLASS FITTINGS

H3060B Series



H3060B (Previous Model: H3061B)



H3060B21 (Previous Model: H3062B)

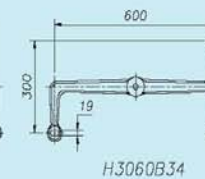
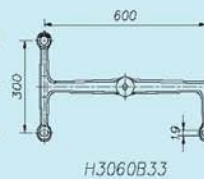
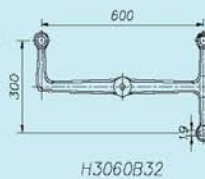
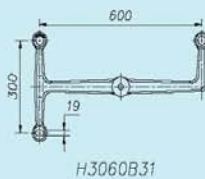
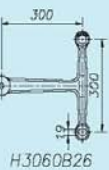
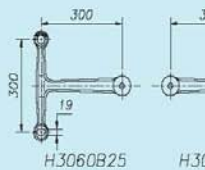
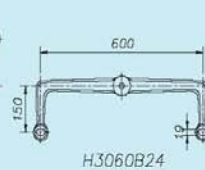
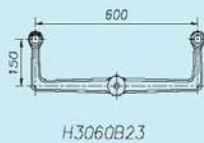
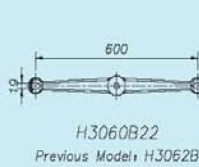
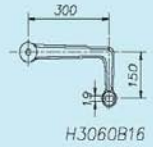
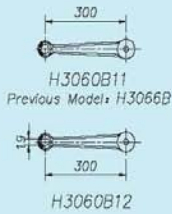
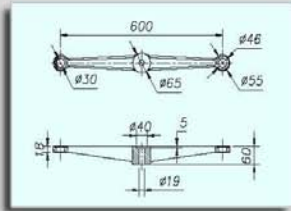
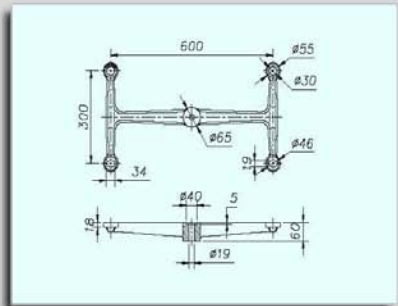

H3070A Series



H3070A (Previous Model: H30701)



H3070A21 (Previous Model: H30702)

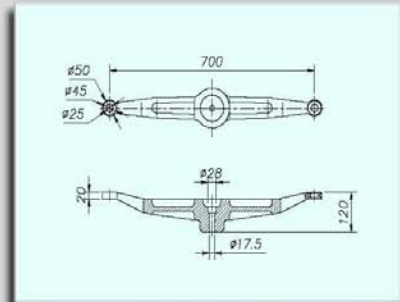
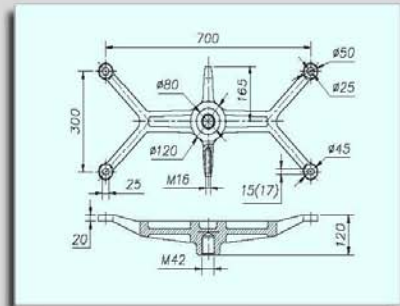

H4706 Series



H4706K (Previous Model: HW3001)



H4706G

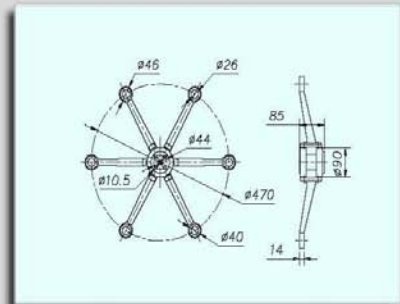
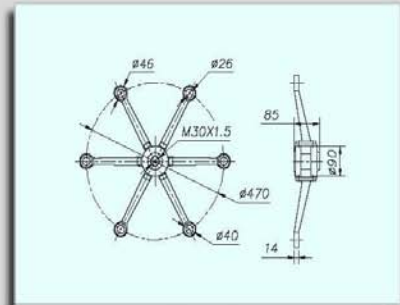

IN ARCHITECTURAL GLASS FITTINGS

H2542T Series

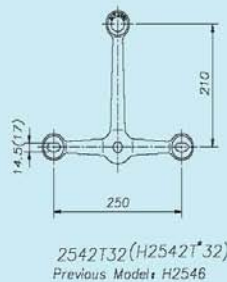
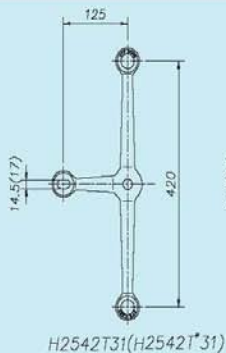
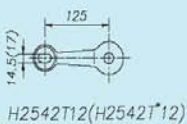
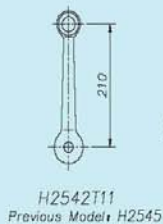
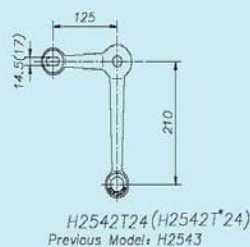
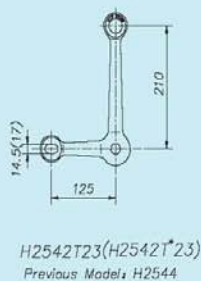
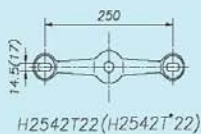
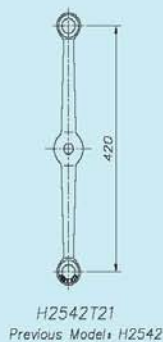
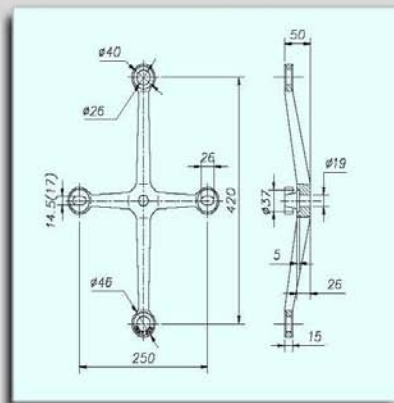

HJ3030T Series

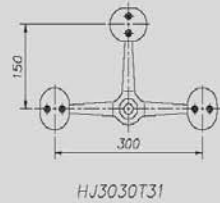
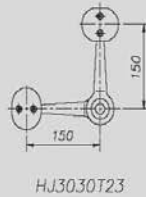
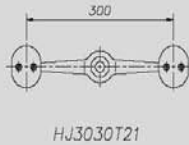
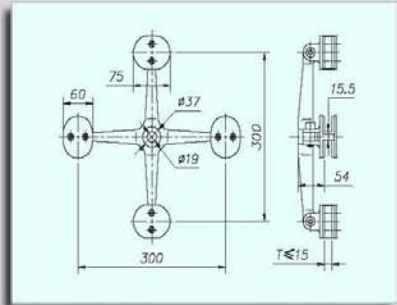

H3535T Series

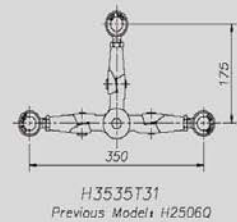
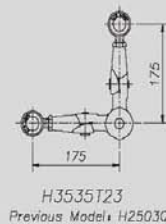
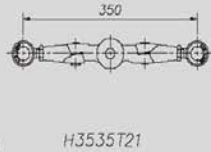
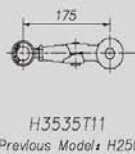
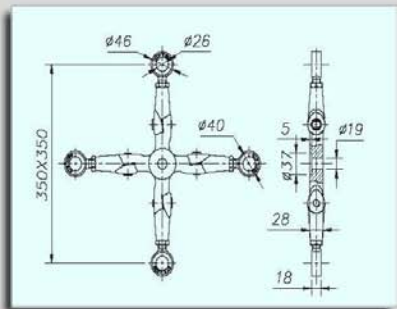

IN ARCHITECTURAL GLASS FITTINGS

H3060T Series

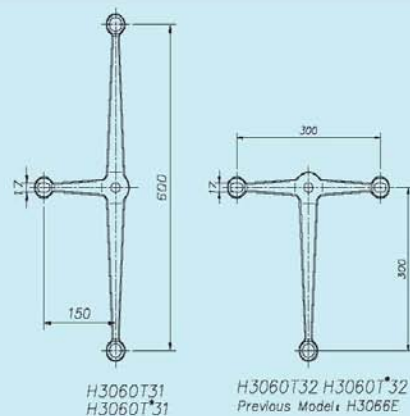
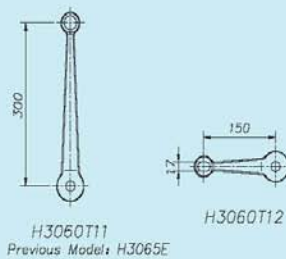
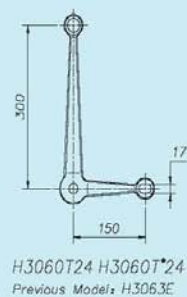
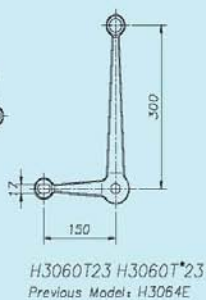
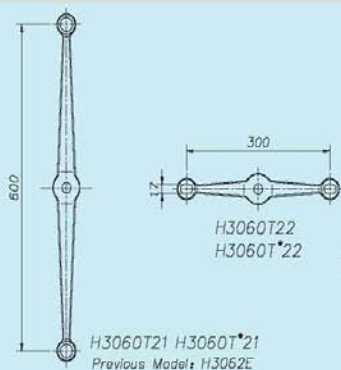
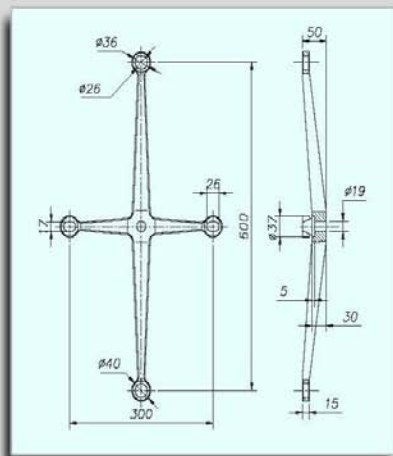



HL210A1

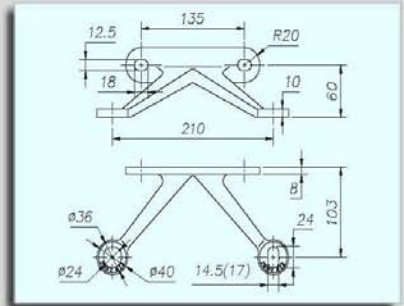

HL210A2

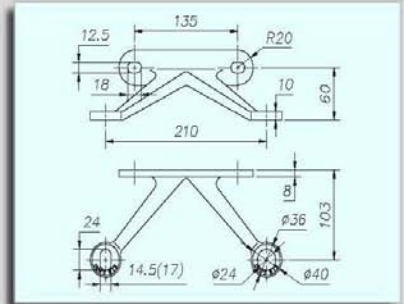

HL210A3

HL210A7
(Previous Model: HQ2102a)



HL210A4



HL210A5



HL210A6

IN ARCHITECTURAL GLASS FITTINGS



HL220A1 (Previous Model: HL01)

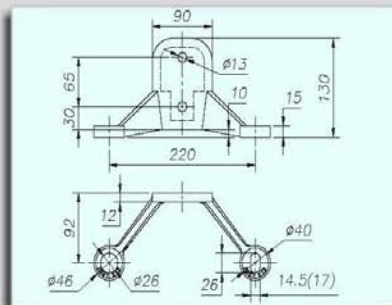

HL220A2 (Previous Model: HL02)

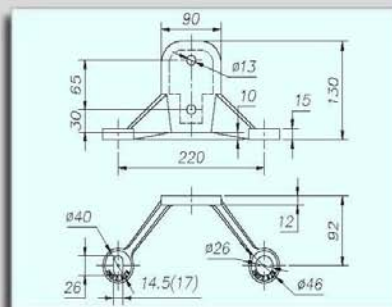

HL220A3 (Previous Model: HL04)



HL220A4 (Previous Model: HL08)



HL220A5 (Previous Model: HL07)



HL220A6 (Previous Model: HL03)



HL220B1 (Previous Model: HL14)

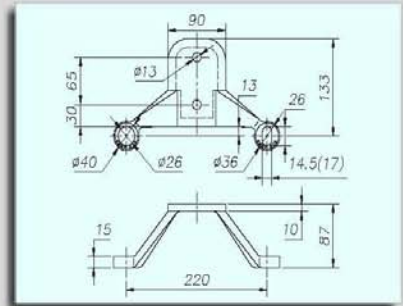

HL220B2 (Previous Model: HL15)

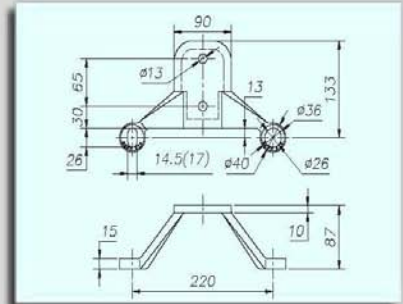

HL220B3 (Previous Model: HL19)



HL220B4 (Previous Model: HL18)



HL220B5 (Previous Model: HL16)



HL220B6 (Previous Model: HL17)

IN ARCHITECTURAL GLASS FITTINGS



HL220C1

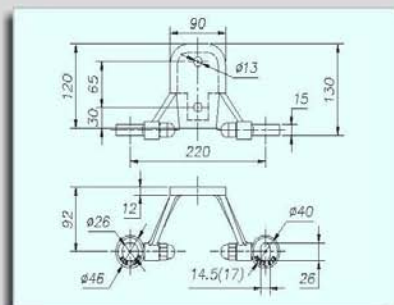

HL220C2

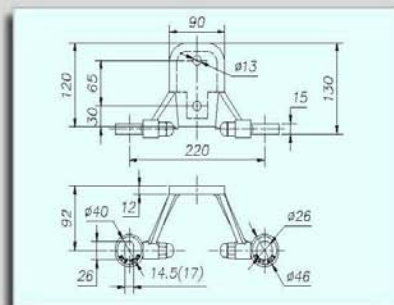

HL220C3



HL220C4



HL220C5



HL220C6



HL250A1 (Previous Model: HL2501A-F)

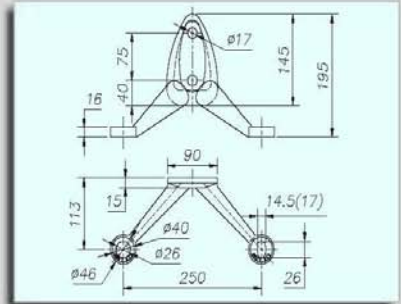

HL250A2 (Previous Model: HL2502A-F)

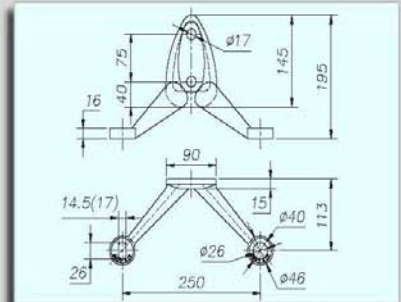

HL250A3 (Previous Model: HL2503A-F)



HL250A4 (Previous Model: HL2504A-F)



HL250A5 (Previous Model: HL2506A-F)



HL250A6 (Previous Model: HL2505A-F)

IN ARCHITECTURAL GLASS FITTINGS



HL250B1 (Previous Model: HL2502)

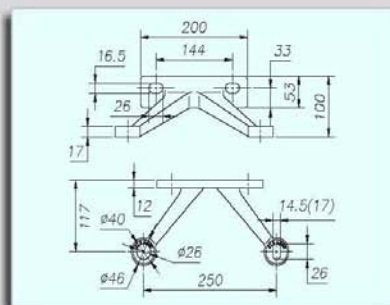

HL250B2 (Previous Model: HL2501)

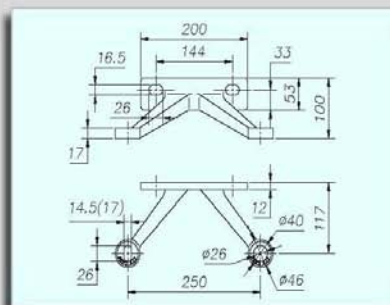

HL250B3 (Previous Model: HL2507)



HL250B4
(Previous Model: HL2508)

HL250B7
(Previous Model: HL2503)



HL250B5 (Previous Model: HL2506)



HL250B6 (Previous Model: HL2505)



HL250C1

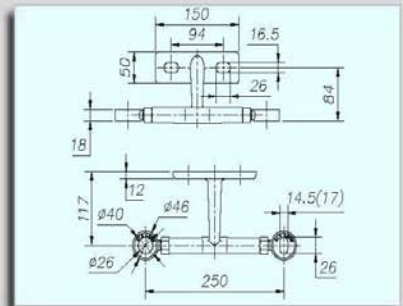

HL250C2 (Previous Model: HL2504)

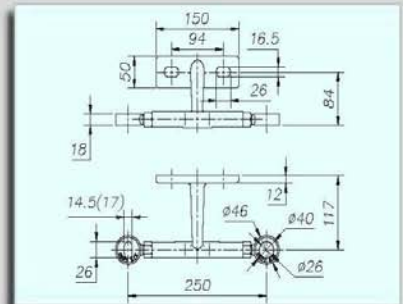

HL250C3



HL250C4



HL250C5



HL250C6

IN ARCHITECTURAL GLASS FITTINGS



HL250D1 (Previous Model: HL2510)

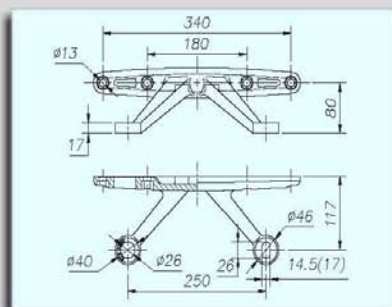

HL250D2 (Previous Model: HL2509)

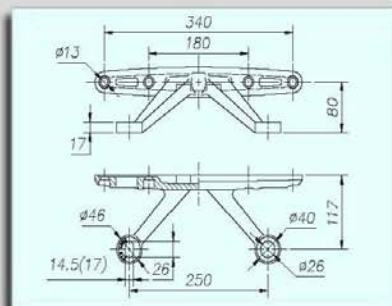

HL250E1 (Previous Model: HL2503C)

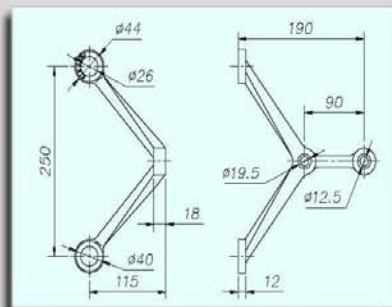

HL250E7 (Previous Model: HL2501C)

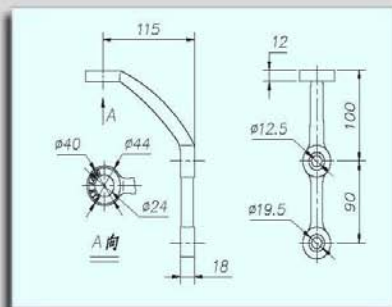



HL250F1 (Previous Model: HL2501D)

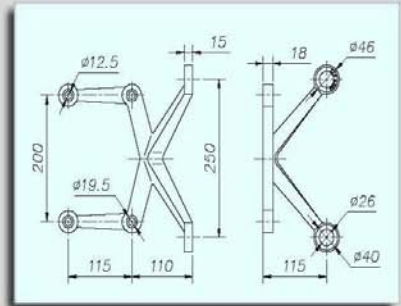

HL250G2 (Previous Model: HL2501E)

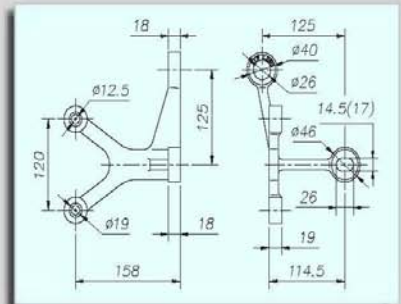

Example of glass fin spider

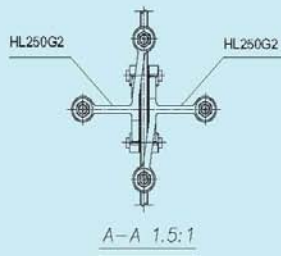
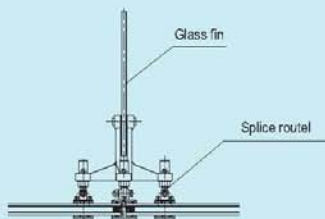
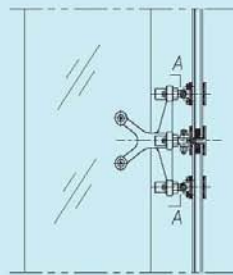
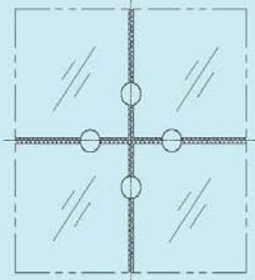

IN ARCHITECTURAL GLASS FITTINGS



HL250H1

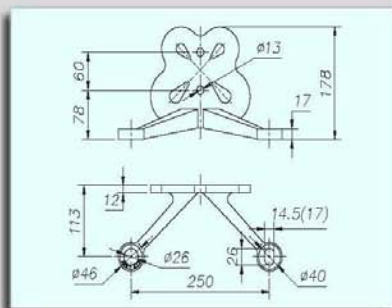

HL250H2

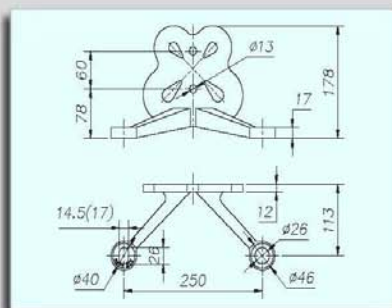

HL250H3



HL250H4



HL250H5



HL250H6



HL265A1 (Previous Model: HL2651)

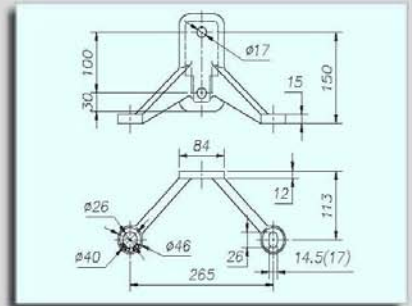

HL265A2 (Previous Model: HL2652)

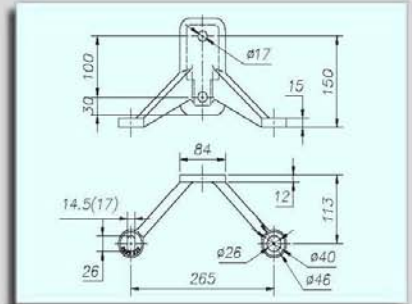

HL265A3 (Previous Model: HL2653)



HL265A4 (Previous Model: HL2655)



HL265A5 (Previous Model: HL2656)



HL265A6 (Previous Model: HL2654)



HL300A (Previous Model: HL06A)

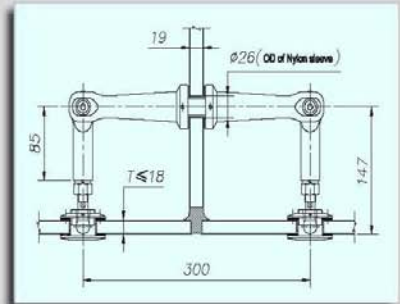

HL300B (Previous Model: HL06B)

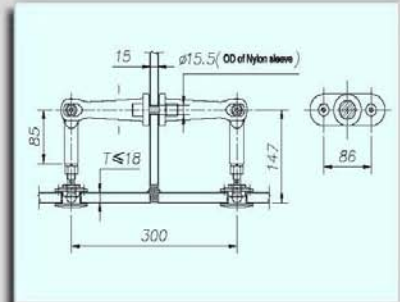

HL300C (Previous Model: HL06C)

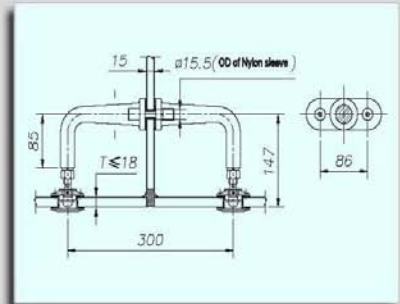

HL300CY (Previous Model: HL06D)

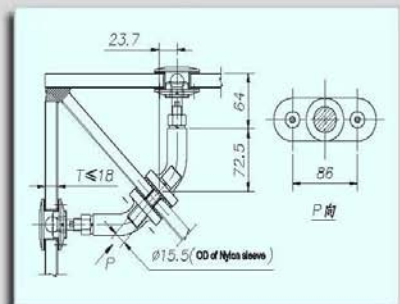

IN ARCHITECTURAL GLASS FITTINGS



HL300CN (Previous Model: HL06E)

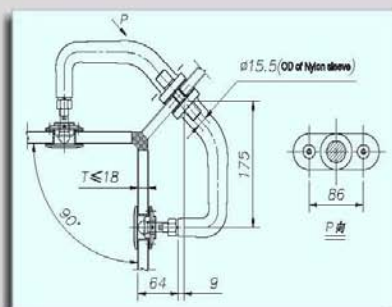

HL300D (Previous Model: HL06F)

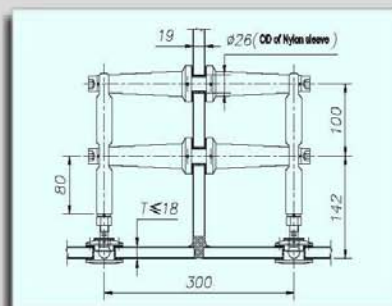

HL300E (Previous Model: HL06N)

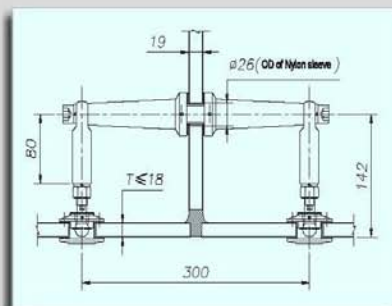

HL300F (Previous Model: HL06W)

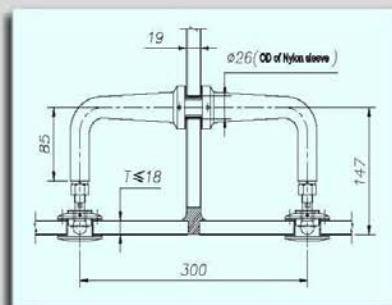

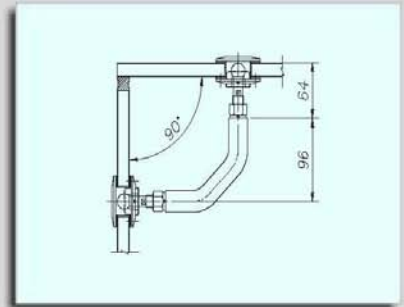

Spring Spider



HDT01 (Previous Model: HTH01)

The shape of DT01 is a product of its function and anti-vibration, which is to transfer the load of the glass and exerted to glass into the support structure across the spring "fuse" (especially for longer span glass glazing system). The V-geometry

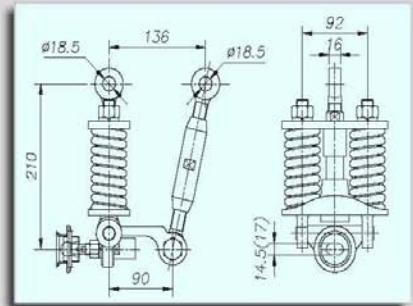

of the assembly divides the loads of the glass weight into an oblique tension component through the spring assembly and into a horizontal compression component through the compression strut or body part of the assembly. The glass is hung from this assembly by articulated bolt. Generally speaking, the spring assembly must remain fixed under loads of up to 7.5kN; but when loads above the threshold are applied, it must sag. The more load exerted, the more sagging deflection of the spring.

Concealed glass suspension clamp



HDY11 (Previous Model: HKLA)

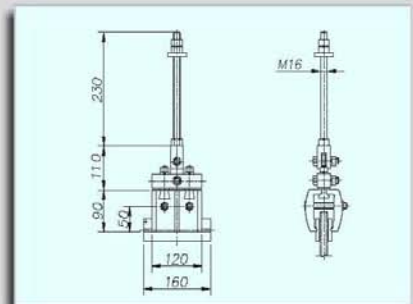

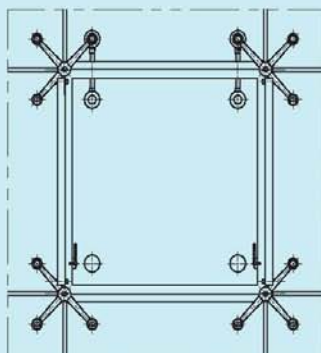
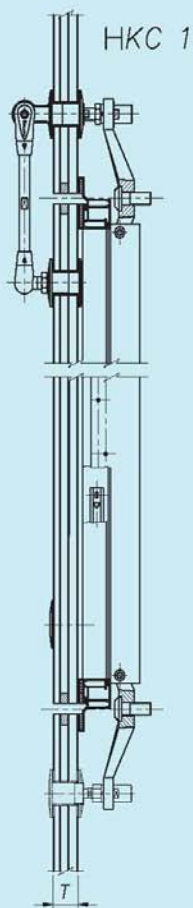

HKC1 will be incorporated when the weight of openable window sash over 100Kg

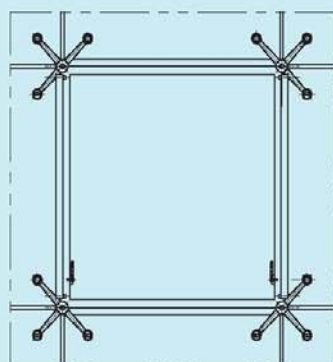

1. HKC2 will be incorporated when the weight of openable window sash less than 100Kg
2. There is no use to incorporate stay in the event that the height of window is less than 700mm

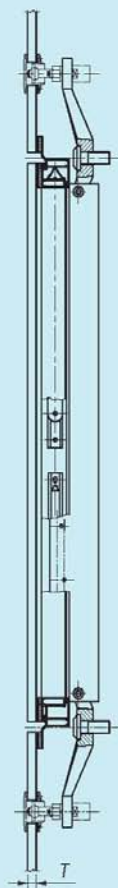

IN ARCHITECTURAL GLASS FITTINGS

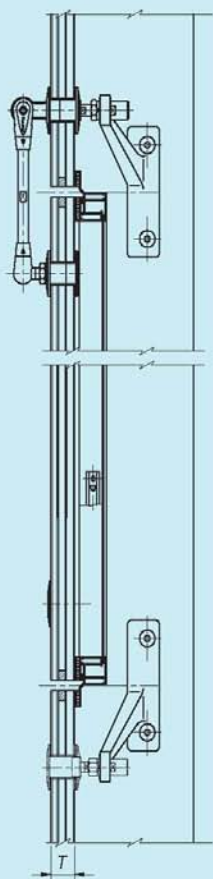

HKC 3

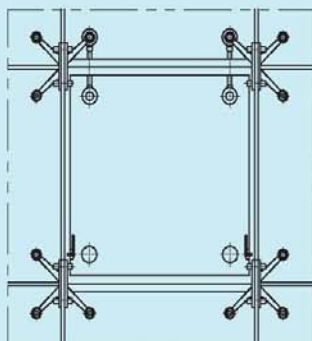

HKC3 will be incorporated when the weight of openable window sash over 100Kg

HKC 4

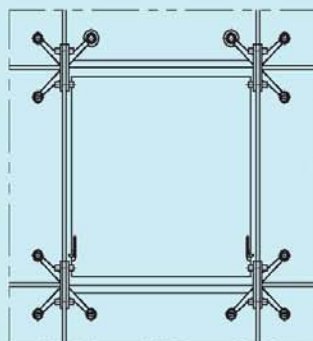

1. HKC4 will be incorporated when the weight of openable window sash less than 100Kg
2. There is no use to incorporate stay in the event that the height of window is less than 700mm

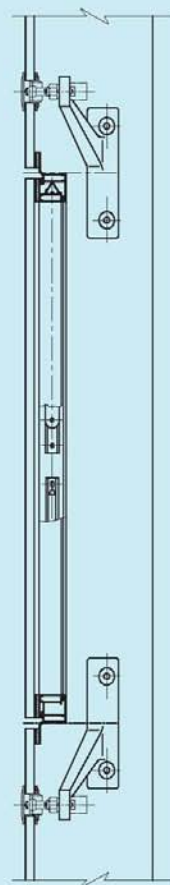



H250 □ 31

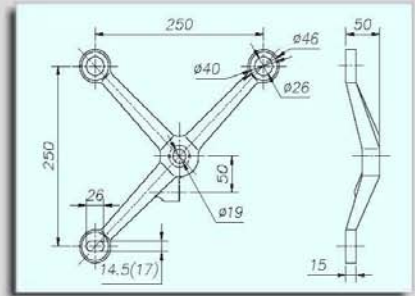

H250 □ 32

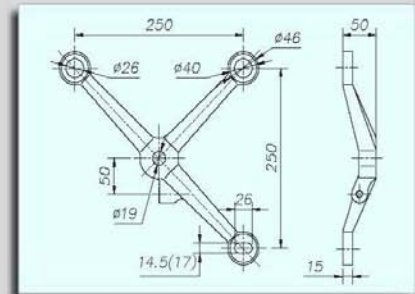

H250 □ 33

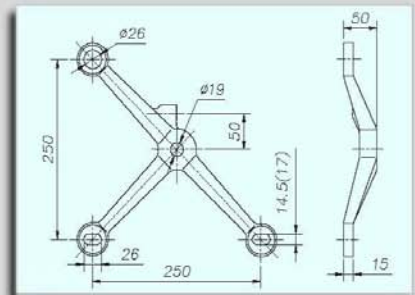

H250 □ 34

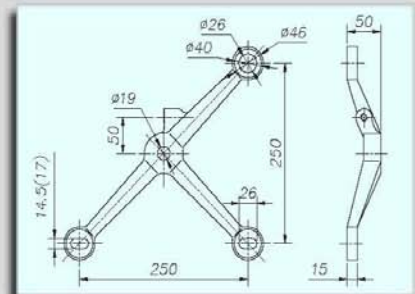

Typical spider system assembly (welded to steel structure)

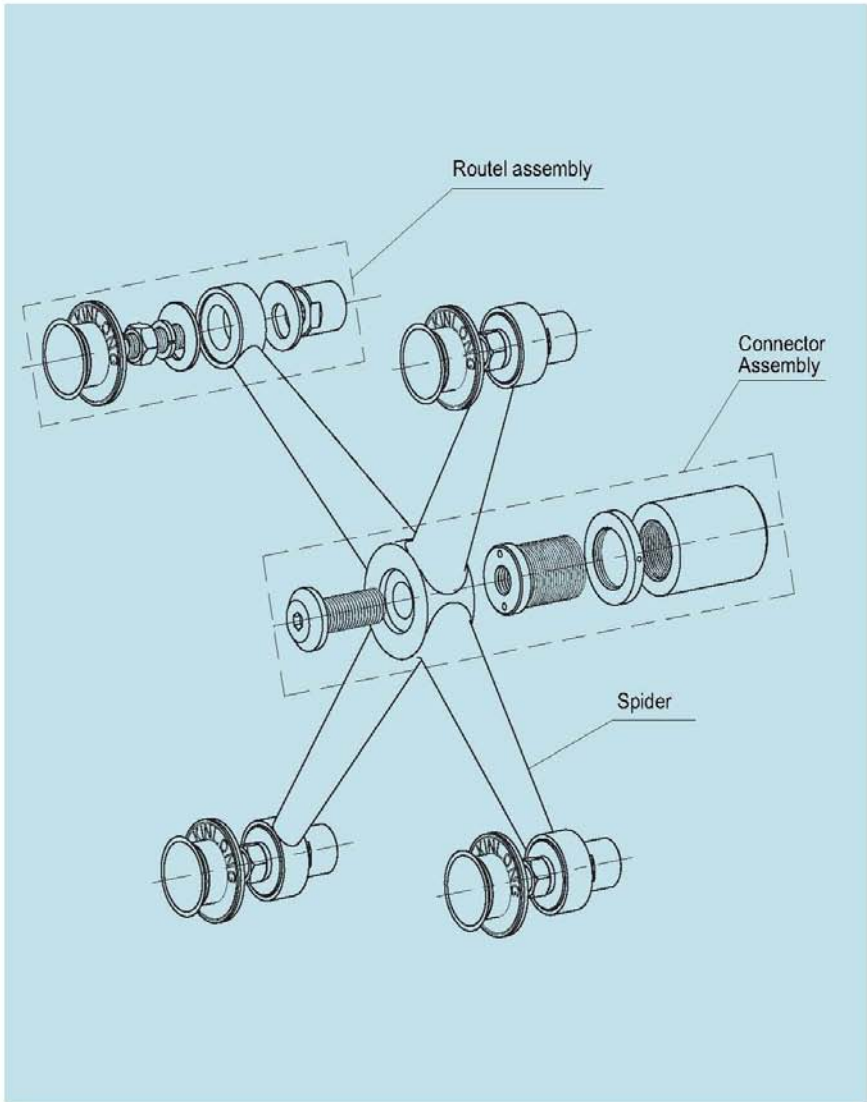

IN ARCHITECTURAL GLASS FITTINGS

Reference design load of routel (Material S.S. 316 and S.S.304)

No.	Routel name	Design axial load capability, N* (Negative windload)	Design radial load capability, N* (Dead - Weight)	L
1	HTF11、HTF13	4500	2000	60
2	HTF12	4500	2000	62
3	HTF14	4500	1600	68
4	HTF21、HTF22、HTF23	4500	2000	60
5	HTF31	6000	2500	82
6	HTF41	6000	2500	81
7	HTF42	4500	2000	65
8	HTF43	4500	2000	57
9	HTF51	6000	2500	65
10	HTF81	2500	1200	55
11	HTF82	2500	1200	42
12	HTF83	4500	2000	45
13	HTF84	4500	2000	40
14	HTC11	4500	2000	64
15	HTC12	4500	2000	59
16	HTC13	4500	2000	64
17	HTC14	4500	2000	55
18	HTC21	6000	2500	82
19	HTC42	4500	2000	74
20	HTC43	4500	2000	63
21	HTC81	2500	1200	54
22	HTC82	2500	1200	42
23	HTJ11、HTJ12、HTJ13	6000	2500	73-93
24	HTJ15、HTJ16、HTJ25	6000	2000	59-77
25	HTJ21、HTJ23	6000	2500	73-93

* Design values shown in the table are considered acceptable in China, and may not be adequate to fulfill acceptance criteria in other countries. For more stringent requirements, it is suggested to multiply the values in the table with a factor of 0.8. It would be even better for the designer user to test for adequacy against relevant national standard before use.

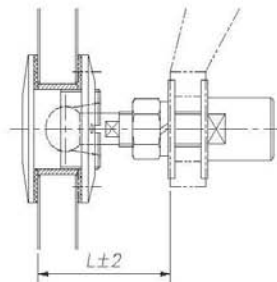

When length L or any design load exceeds the value indicated in the above table, the designer should verify the strength of the head bolt based on the design loading conditions

Flat cap routel



HTF11 (Previous Model: HT02)

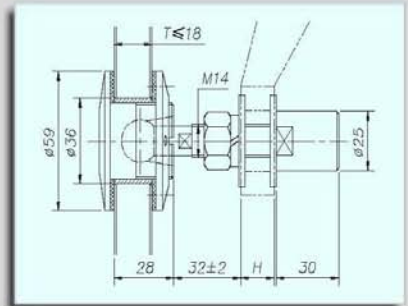

HTF12 (Previous Model: HT02B)

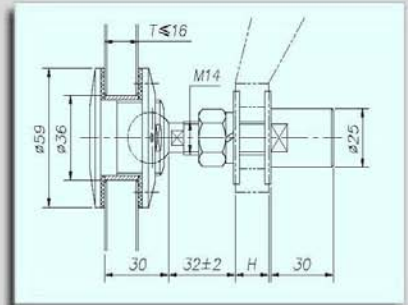

HTF13 (Previous Model: HT02C)

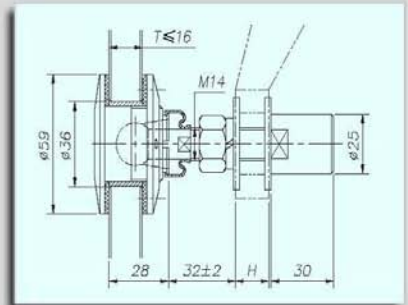

HTF14 (Previous Model: HT02D)

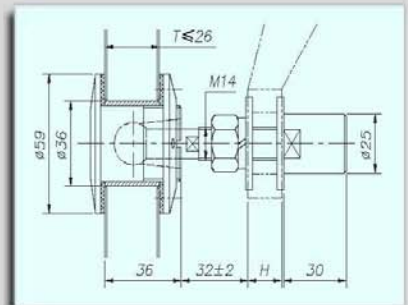

IN ARCHITECTURAL GLASS FITTINGS

Flat cap routel



HTF21 (Previous Model: HT02E)

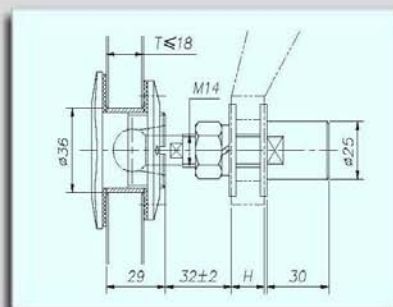

HTF22 (Previous Model: HT02F)

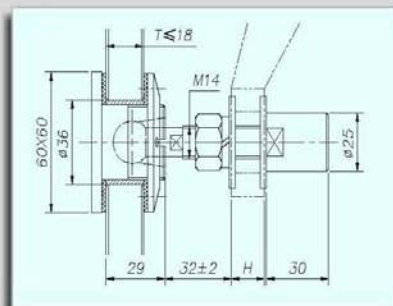

HTF23 (Previous Model: HT02G)

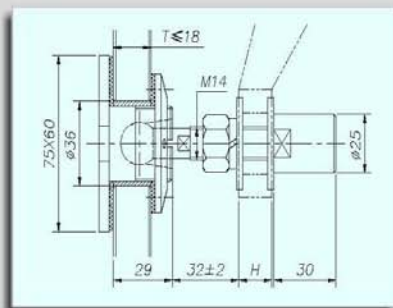

HTF31 (Previous Model: HT03)

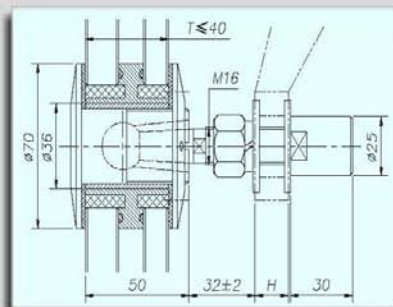

Flat cap routel



HTF41 (thermal insulated)
(Previous Model: HT04)

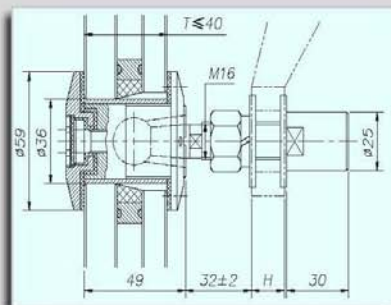

HTF42 (Previous Model: HT11A)

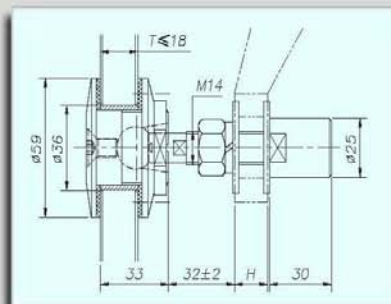

HTF43

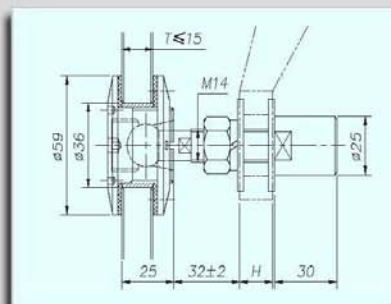

HTF51 (Previous Model: HT10)

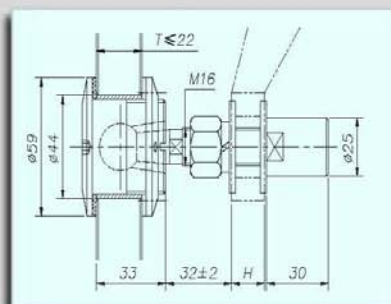

IN ARCHITECTURAL GLASS FITTINGS

Flat cap routel



HTF81 (Previous Model: HT06A)

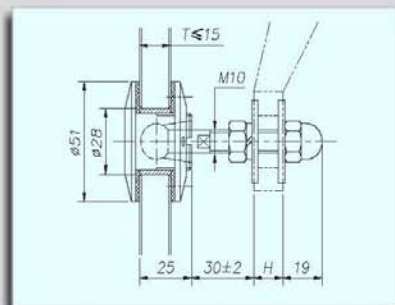

HTF82 (Previous Model: HT16A)

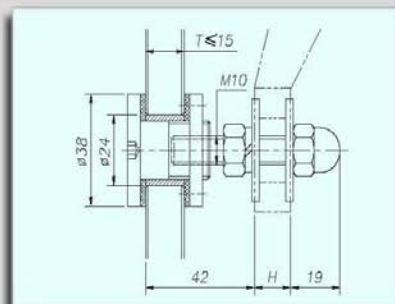

HTF83 (Previous Model: HT07A)

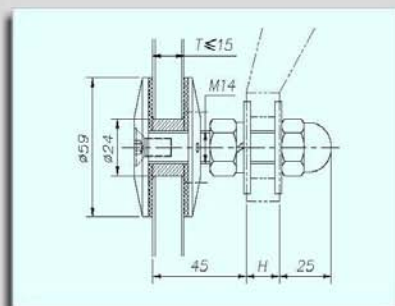

HTF84 (Previous Model: HT17)

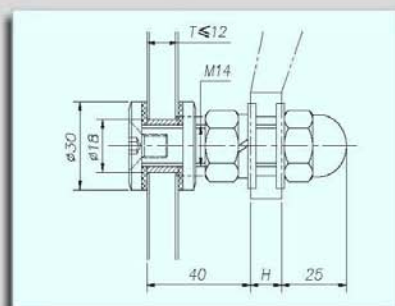

Countersunk routel



HTC11 (Previous Model: HT01)

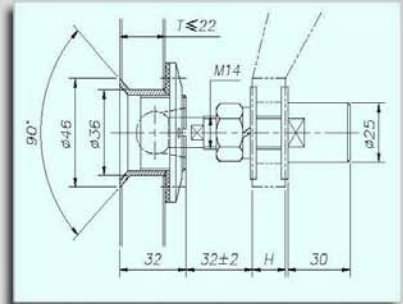

HTC12 (Previous Model: HT01B)

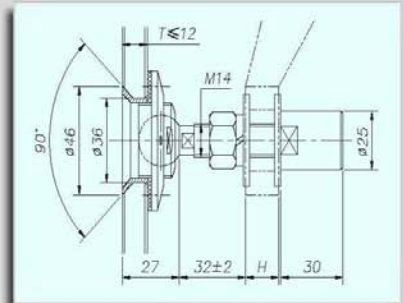

HTC13 (Previous Model: HT01C)

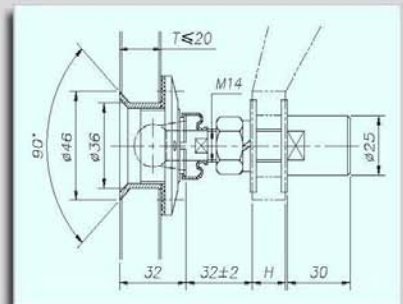

HTC14 (Previous Model: HT14A)

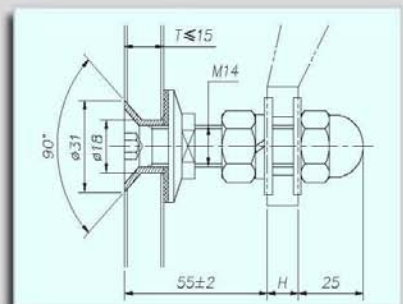

IN ARCHITECTURAL GLASS FITTINGS

Countersunk routel



HTC21 (Previous Model: HT08)

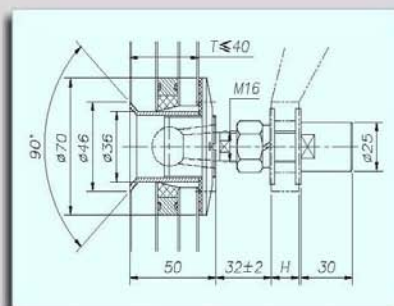

HTC42 (Previous Model: HT12B)

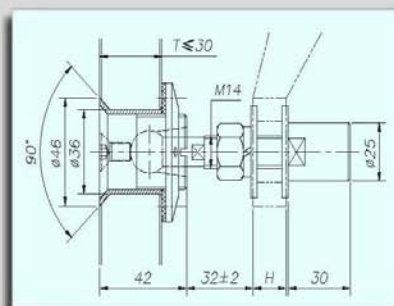

HTC43

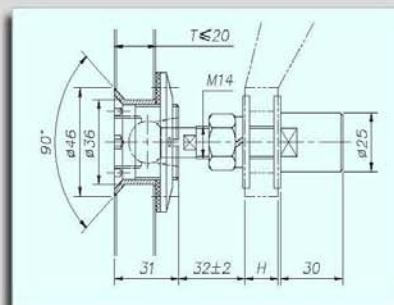

HTC81 (Previous Model: HT13)

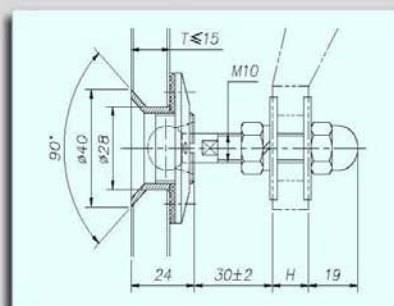

Countersunk Routel



HTC82 (Previous Model: HT15A)

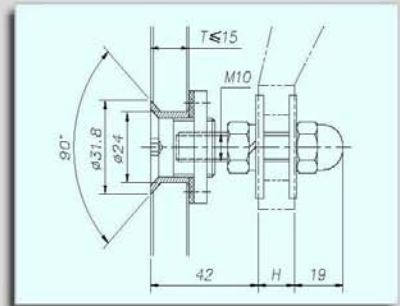

Applicable: HTC11-HTC13, HTC42, HTC43

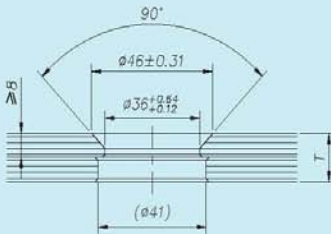

Applicable: HTC11-HTC13, HTC42, HTC43

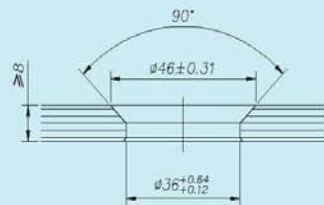

Applicable: HTC14

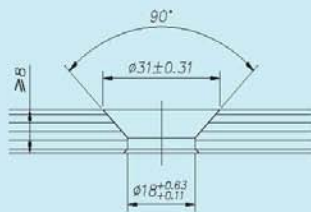

Applicable: HTC21

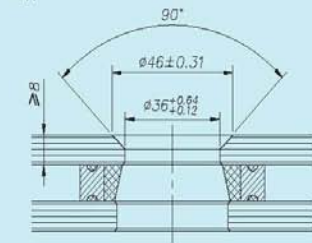

Applicable: HTC81

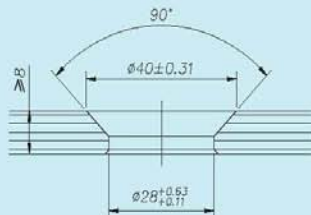

Applicable: HTC82

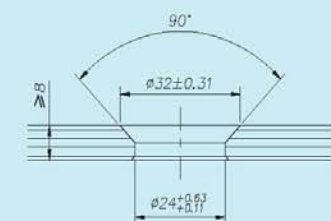

Glass Drilling

Applicable: HTF31, HTF41

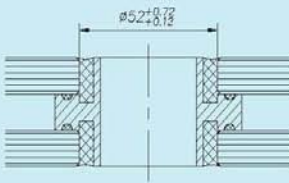

Applicable: HTF31, HTF41

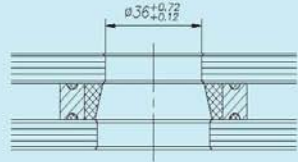

Applicable: HTF11+HTF14, HTF21+HTF23, HTF42, HTF43

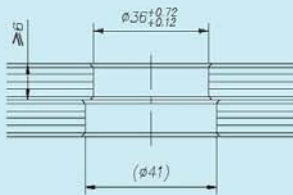

Applicable: HTF84

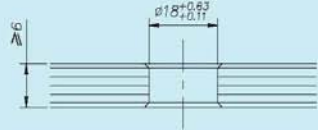

Applicable: HTF11+HTF14, HTF21+HTF23, HTF42, HTF43



Applicable: HTF82, HTF83



Applicable: HTF51

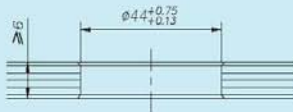

Applicable: HTF81



Al. sleeve for IGU

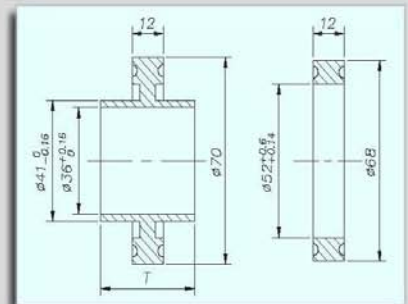

Splice routel



HTJ11 (Previous Model: HJ03C)

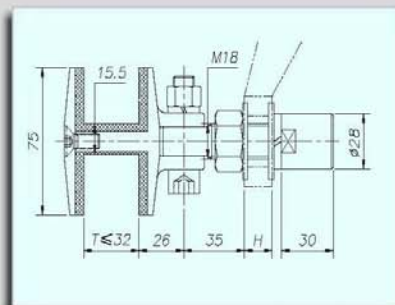

HTJ12 (thermal insulated)

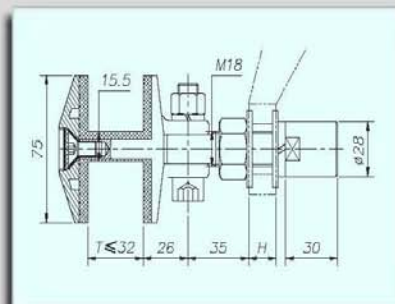

HTJ13 (Previous Model: HJ01C)

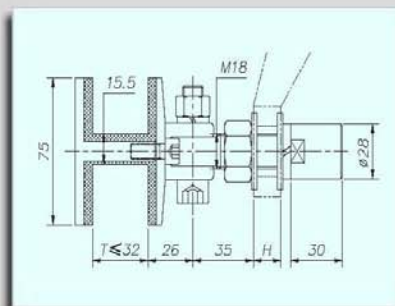

HTJ15 (Previous Model: HJ02C)

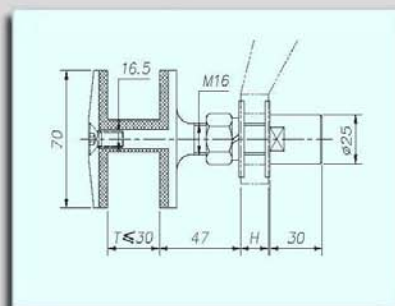

Splice routel



HTJ16 (thermal insulated)

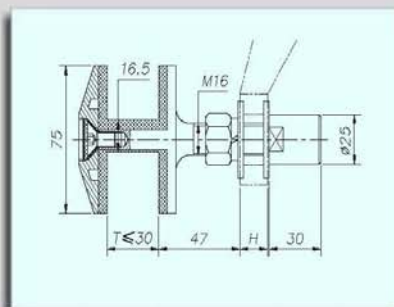

HTJ 21

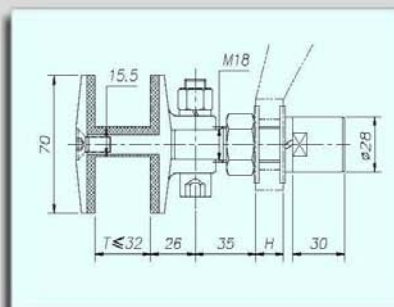

HTJ 23

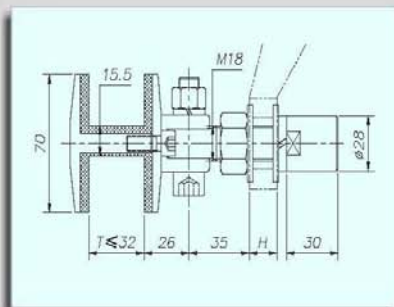

HTJ 25

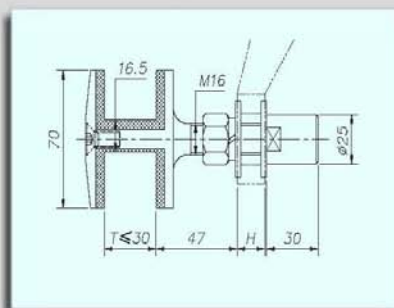

IN ARCHITECTURAL GLASS FITTINGS



HJ120G11 (Previous Model: HSJ-1A)

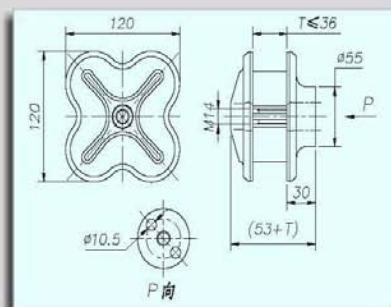

HJ120G21 (Previous Model: HSJ-2A)

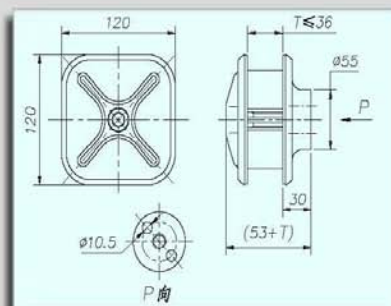

HJ120S11 (Previous Model: HSJ-3B)

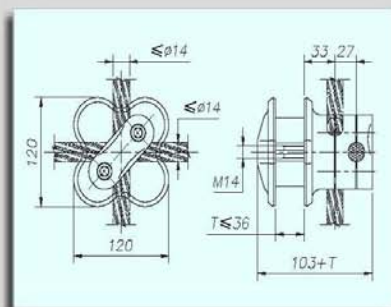

HJ120S21 (Previous Model: HSJ-4A)

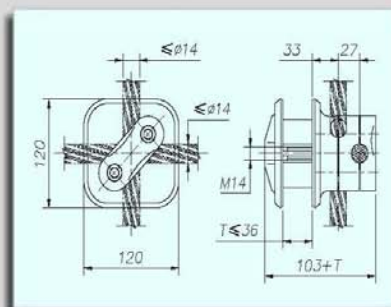



HJ120S12 (Previous Model: HSJ-3C)

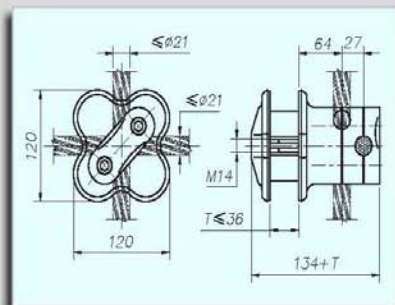

HJ120S22

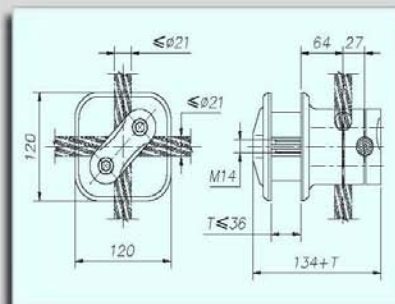

HJ120S13

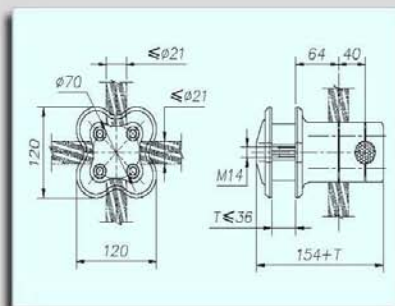

HJ120S23 (Previous Model: HSJ-6C)

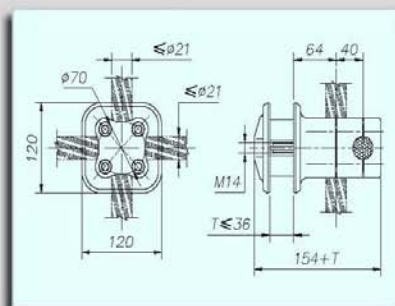

IN ARCHITECTURAL GLASS FITTINGS



HJ120S14

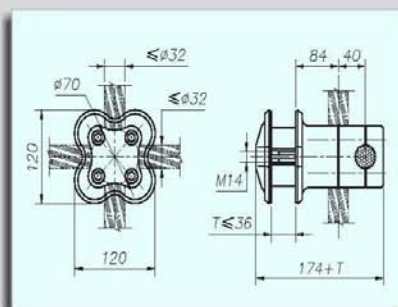

HJ120S24 (Previous Model: HSJ-6B)

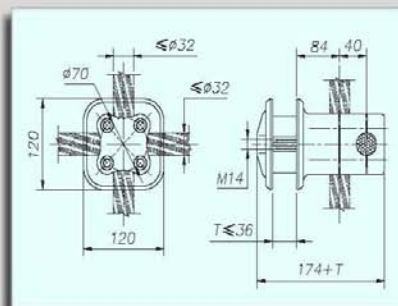

HJ120S15 (Thermal insulated)

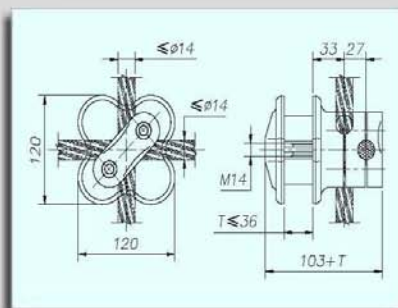

HJ120S25 (Thermal insulated)

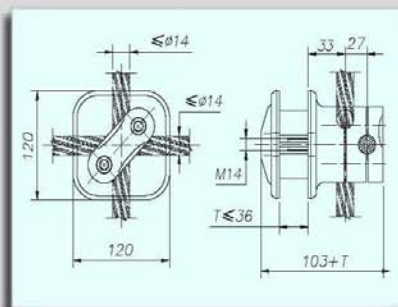



HJ120S16 (Thermal insulated)

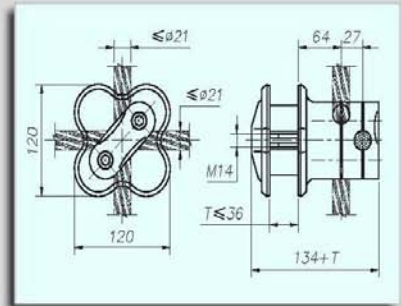

HJ120S26 (Thermal insulated)

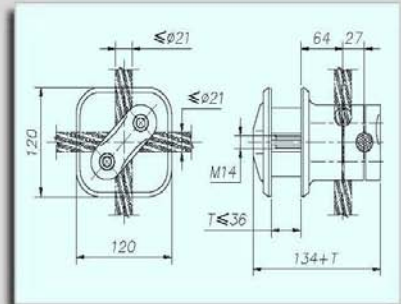

HJ145KX (Previous Model: HSJ-21)

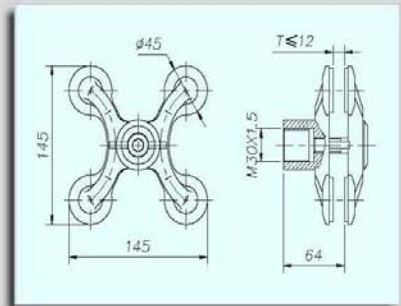

HJ145KH (Previous Model: HSJ-20)

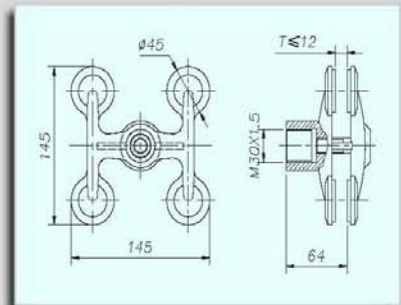

IN ARCHITECTURAL GLASS FITTINGS



HJ150S (Previous Model: HSJ-11A)

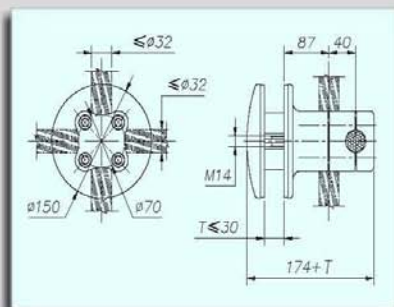

HJ150L (Previous Model: HL-J1)

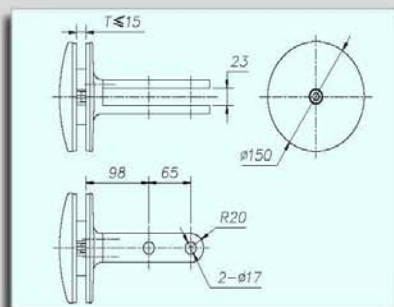

HJ200K1 (Previous Model: HSJ-5)

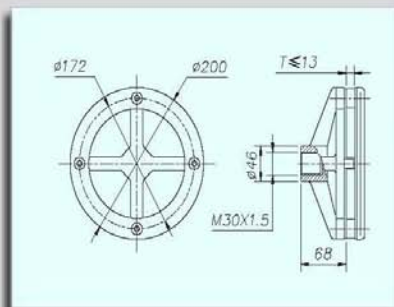

HJ200K2 (Previous Model: HSJ-5B)

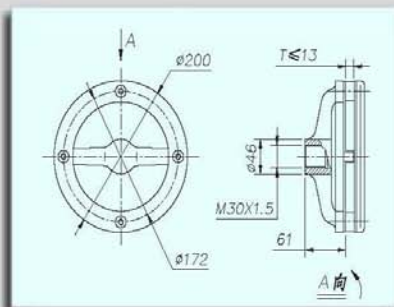



HJ200K3 (Previous Model: HSJ-5A)

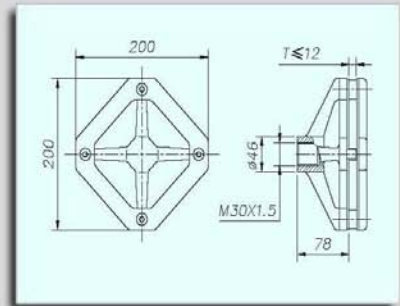

HJ152S1

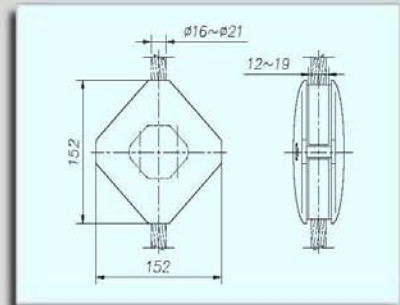

HJ152S2

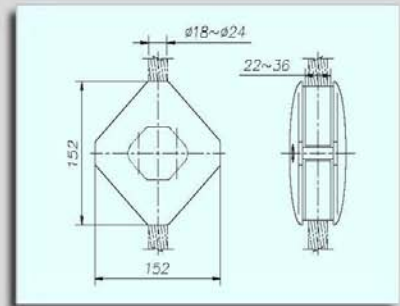

HJ170S1 (Previous Model: HSJ-9A)

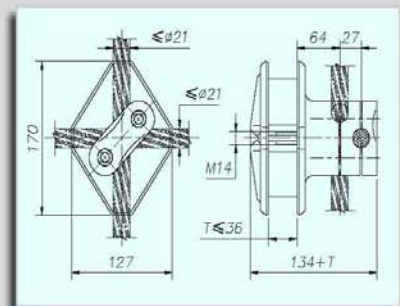

IN ARCHITECTURAL GLASS FITTINGS



HJ170S2 (Previous Model: HSJ-10A)

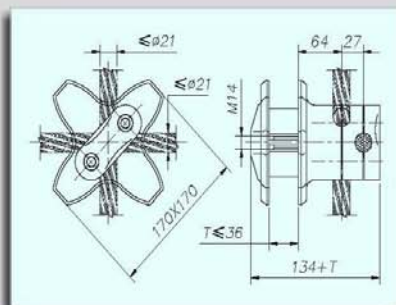

HJ170S3

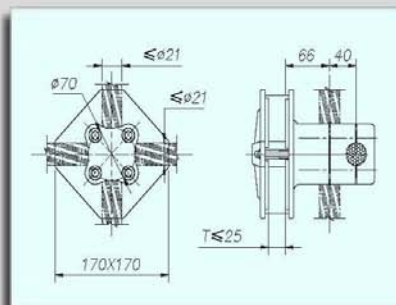

HJ170S4

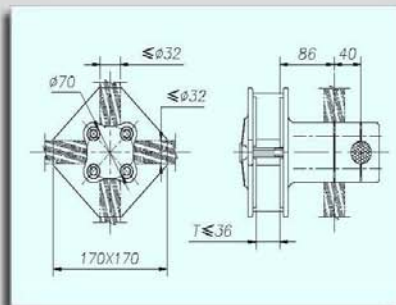

HJ2213S

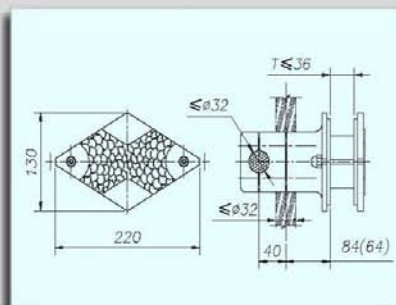

IN ARCHITECTURAL GLASS FITTINGS



HYP21 (Previous Model: HYP-02)

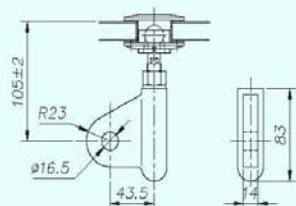

HYP22 (Previous Model: HYP-05)

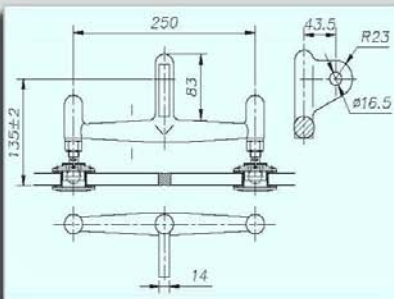

HYP31 (Previous Model: HYP-03)

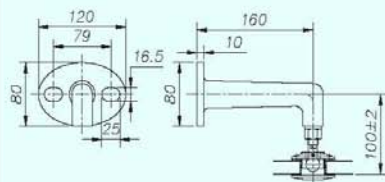

HYP32 (Previous Model: HYP-06)

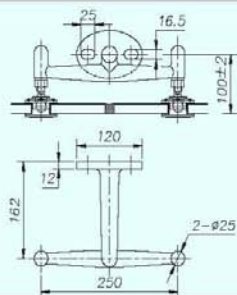

Connector



HZ11

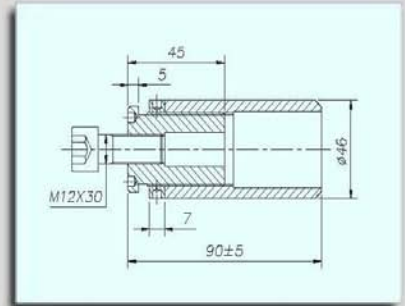

HZ14(Previous Model: HZ01L)

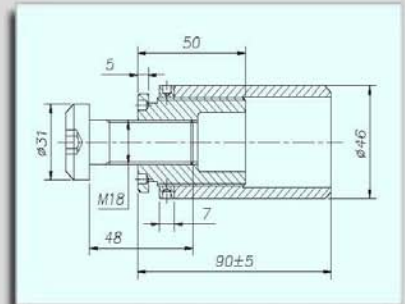

HZ15(Previous Model: HZ01L)

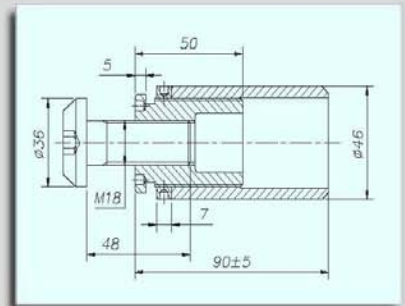

HZ16(Previous Model: HZ01M)

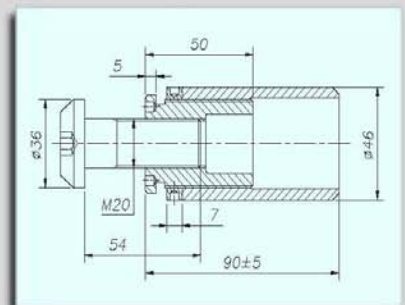

IN ARCHITECTURAL GLASS FITTINGS

Connector



HZ24(Previous Model: HZ01P)

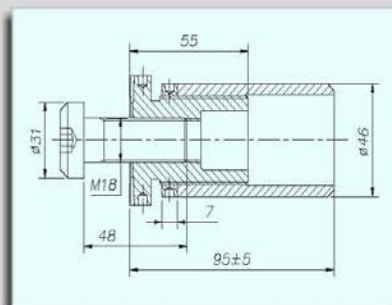

HZ25(Previous Model: HZ01P)

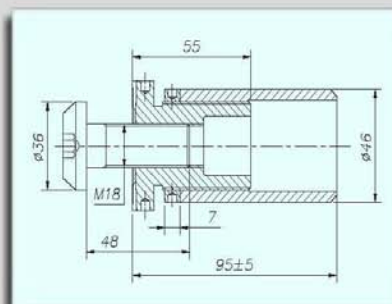

HZ26(Previous Model: HZ01P)

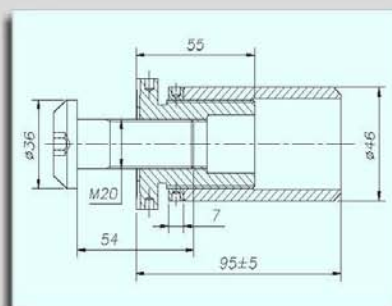

HZ31

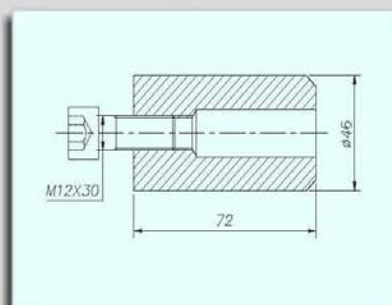

Connector



HZ34(Previous Model: HZ05)

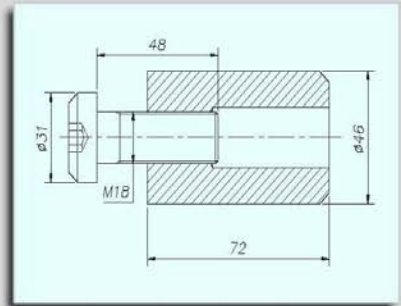

HZ35(Previous Model: HZ05)

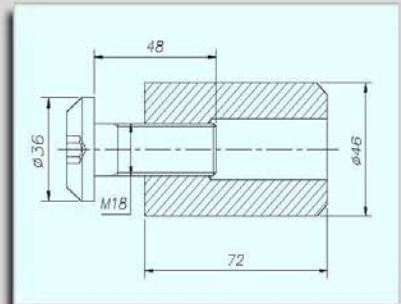

HZ36(Previous Model: HZ05A)

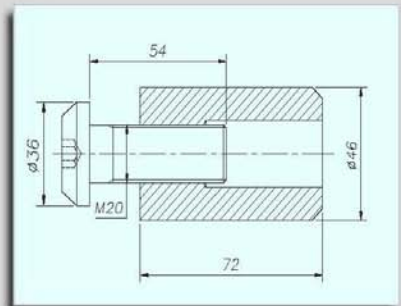

HZ38(Previous Model: HZ02C)

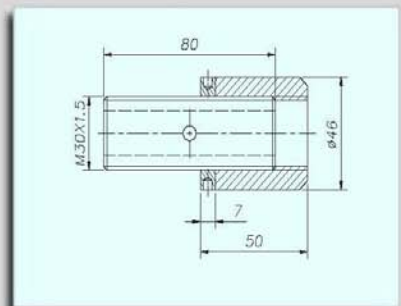

IN ARCHITECTURAL GLASS FITTINGS

Connector



HZ42(Previous Model: HZ01H)

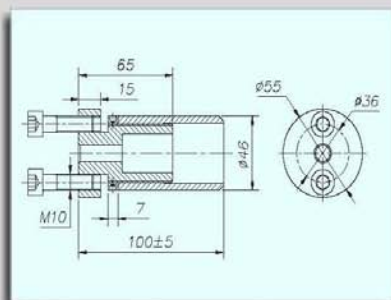

HZ44(Previous Model: HZ01J)

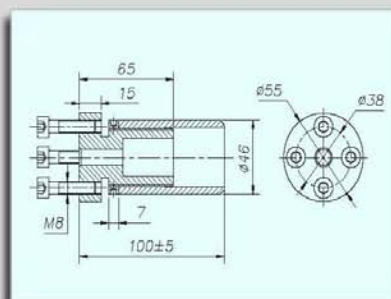

HZ61(Previous Model: HSJ-7A)

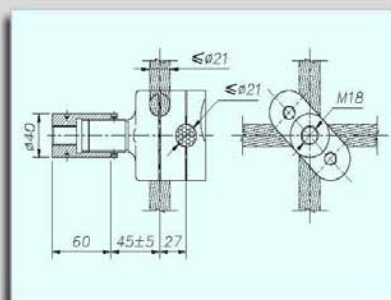

HZ15B

HZ11 ~ HZ44: Unless specified, the base of HZ11 ~ HZ44 will be made of carbon steel Q235. If stainless steel is required, please add suffix "B" to the model. For example, the base of the connector HZ15B in the left photo is made of stainless steel.

Reference design load of Glass Clamp (Material S.S. 316 and S.S.304)

No.	Clamp name	Design axial load capability, N* (Negative windload)	Design radial load capability, N* (Dead load)
1	HJ307S	30000	7000
2	HJ307G	30000	7000
3	HJ308S	24000	7000
4	HJ308Z	24000	7000
5	HJ308L	24000	7000
6	HJ288K	20000	5000
7	HJ257G	20000	5000
8	HJ159K	24000	3500
9	HJ120G	24000	3000
10	HJ120S	24000	3000
11	HJ145KX	20000	2000
12	HJ145KH	20000	2000
13	HJ150S	20000	3500
14	HJ150L	20000	3500
15	HJ200K1	24000	3000
16	HJ200K2	24000	3000
17	HJ200K3	24000	3000
18	HJ152S1	20000	3000
19	HJ152S2	26000	5000
20	HJ170S	24000	3000
21	HJ2213S	24000	3000

* Design values shown in the table are considered acceptable in China, and may not be adequate to fulfill acceptance criteria in other countries. For more stringent requirements, it is suggested to multiply the values in the table with a factor of 0.8. It would be even better for the designer user to test for adequacy against relevant national standard before use.

IN ARCHITECTURAL GLASS FITTINGS



HJ307S (Previous Model: HJJ01A)

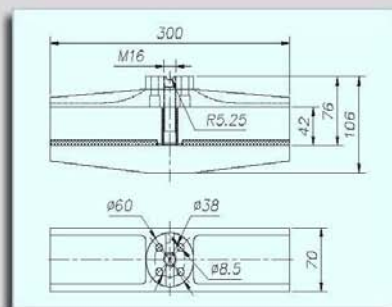

HJ307G (Previous Model: HJJ02A)

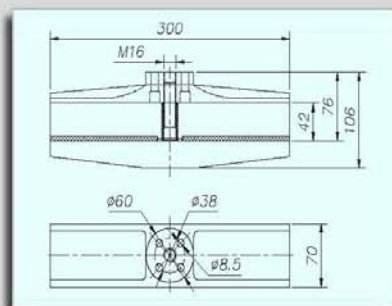

HJ308S (thermal insulated)
(Previous Model: HJJ-7)

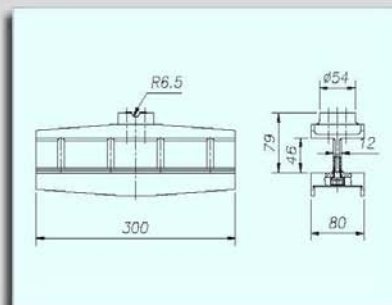

HSJ308Z (thermal insulated)
(Previous Model: HJJ-6)

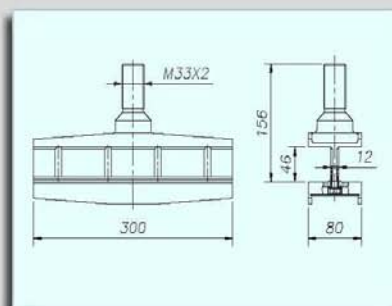



HJ308L (Previous Model: HL-J2)

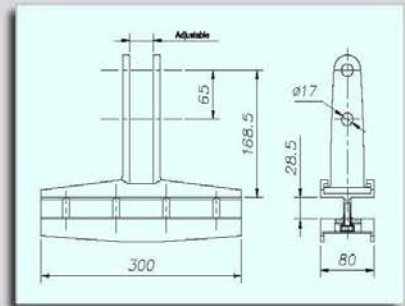

HJ288K (Previous Model: HJJ-12)

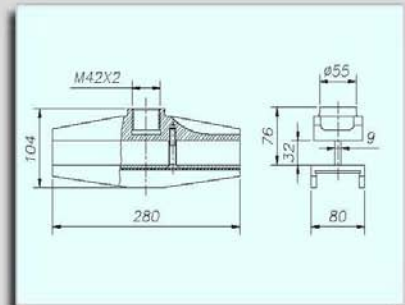

HJ257G (Previous Model: HJJ-11)

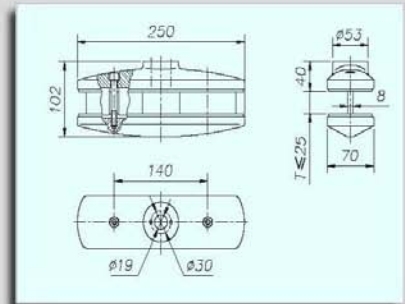

HJ159K (Previous Model: HSJ-8A)

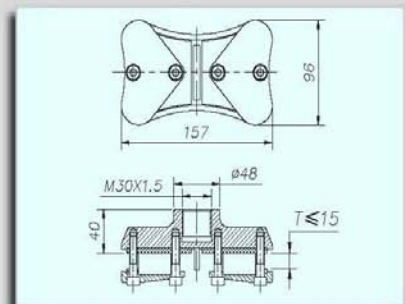

IN ARCHITECTURAL GLASS FITTINGS



HBL31 (Previous Model: HLC1)

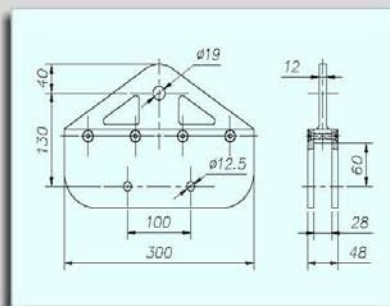

HBL32 (Previous Model: HLC2)

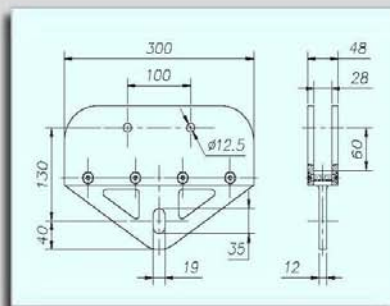

HBL41 (Previous Model: HLD2)

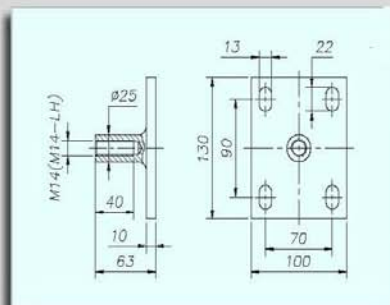

HBL42 (Previous Model: HLD1)

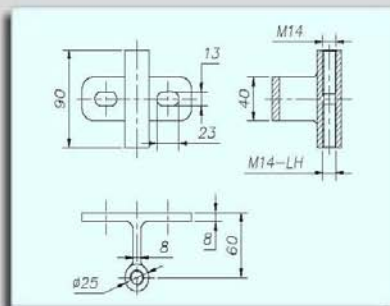

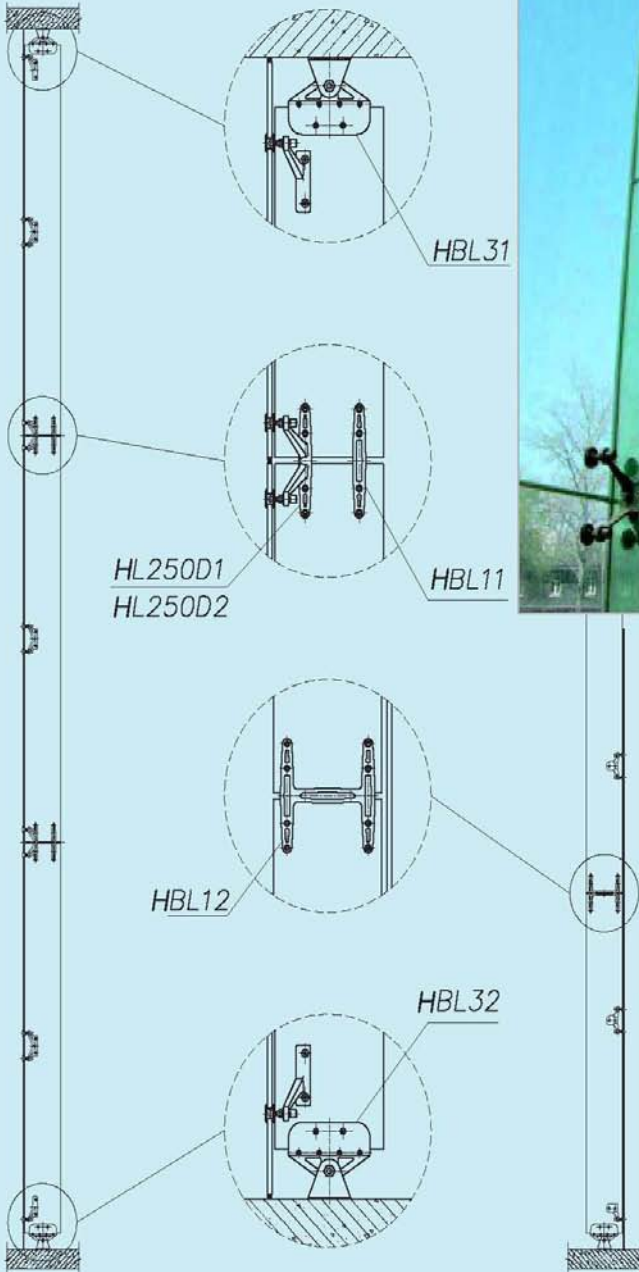

IN ARCHITECTURAL GLASS FITTINGS



HBL11 (Previous Model: HL340/HL340A)

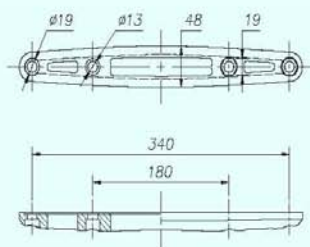

HBL12 (Previous Model: HL340B)

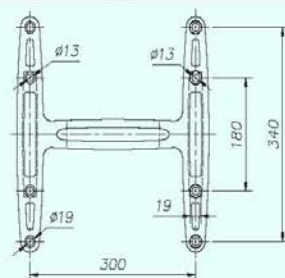

Glass fin suspension system

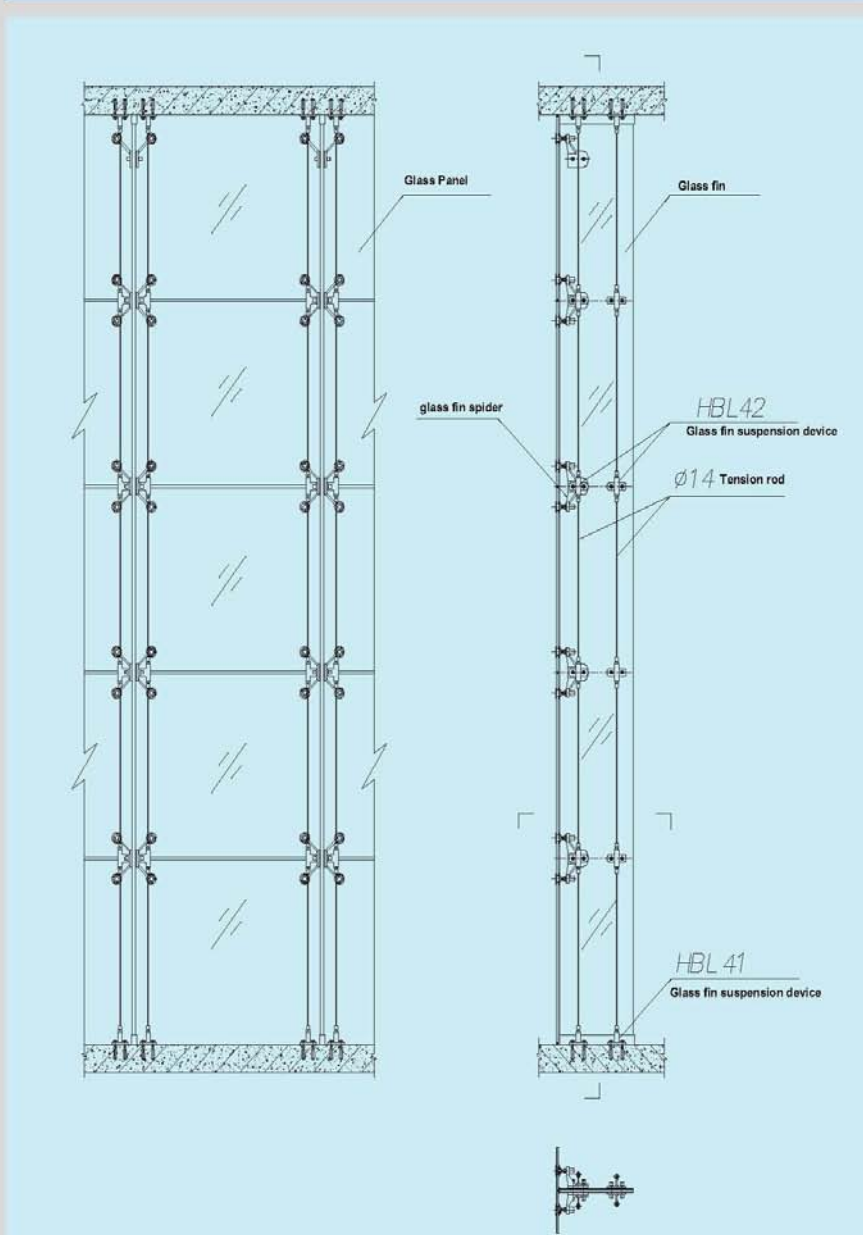



HBL51

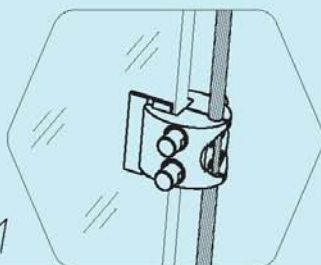

HBL53

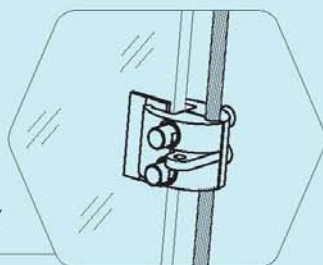

HBL52

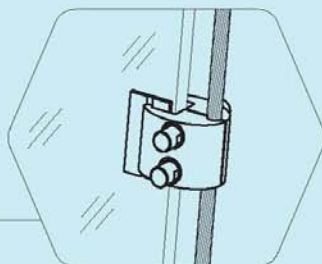

HBL55

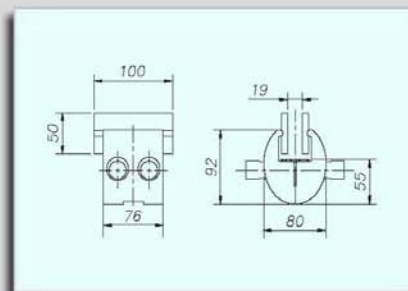

IN ARCHITECTURAL GLASS FITTINGS



HBL51

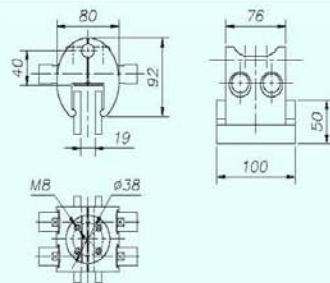

HBL52

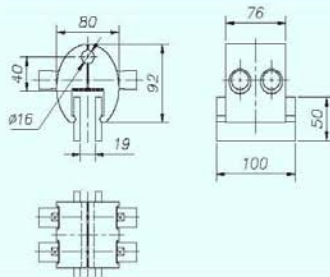

HBL53

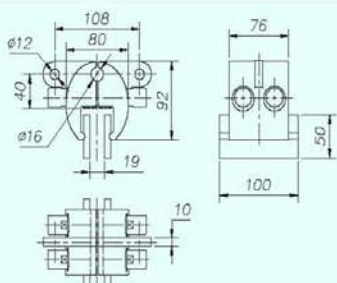

HBL54

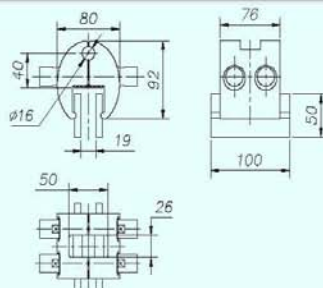

IN ARCHITECTURAL GLASS FITTINGS



HDY11B (Previous Model: HKLA-a)

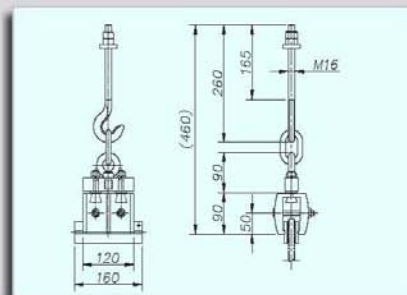

HDY12 (Previous Model: H2KLA)

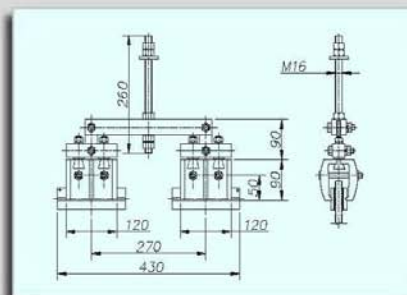

HDY21B (Previous Model: HKLB)

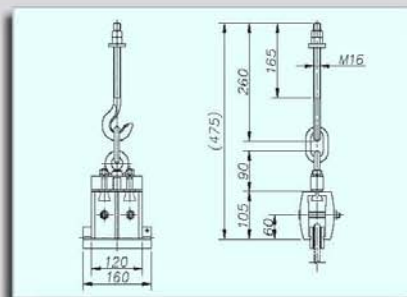

HDY22 (Previous Model: H2KLB)

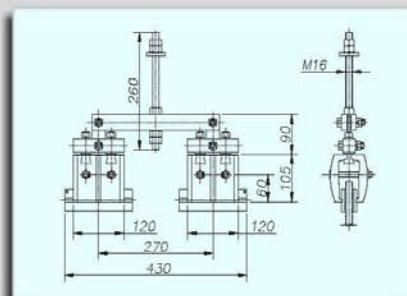

Typical support styles to Cable support system

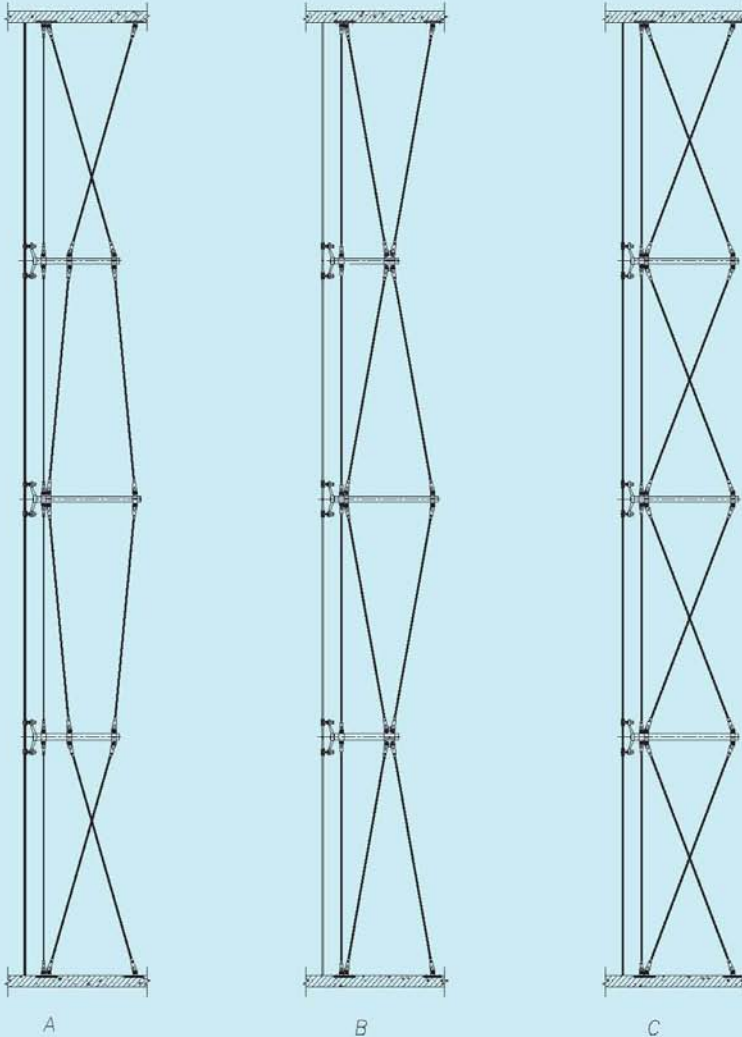

Note: Aforementioned support styles are typical, clients must choose other support styles in accordance with unique project



HGC50-1

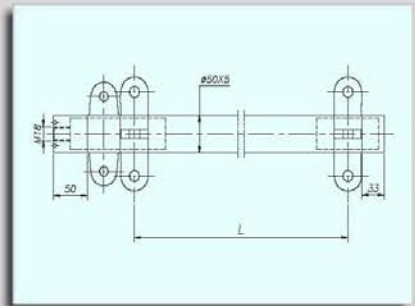

HGC50-2

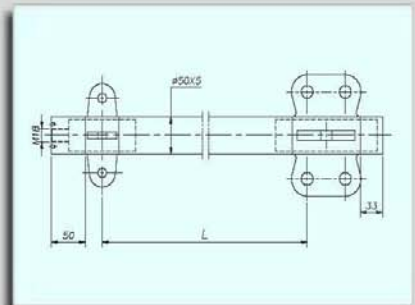

HGC50-3

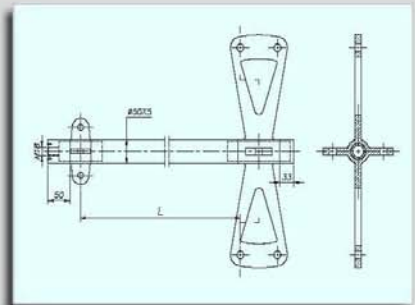

HGC50-4

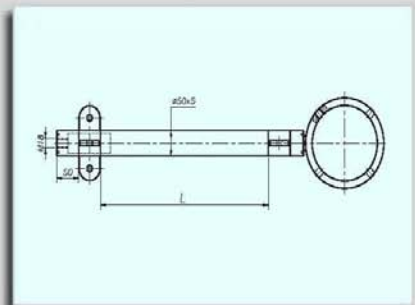

IN ARCHITECTURAL GLASS FITTINGS



HGC50-5

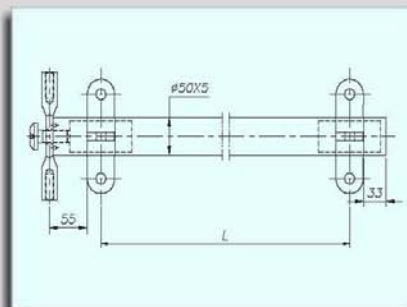

HSGP-01(Previous Model: HG10)

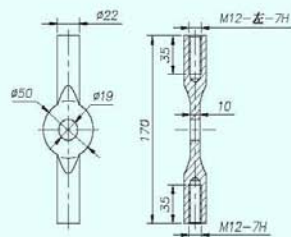

HSGP-02(Previous Model: HS05)

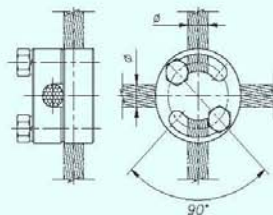

HSGP-03

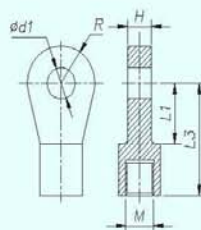



HSC65A

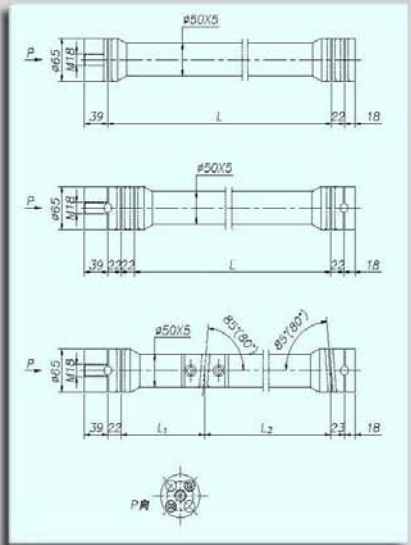

HSC75A

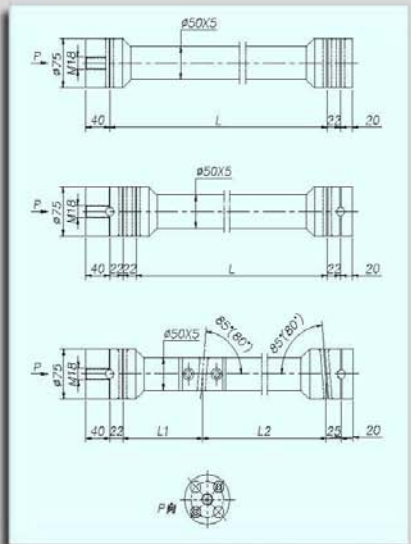



HSC65B

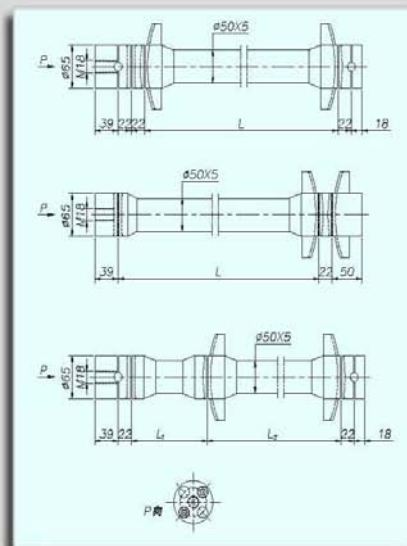

HSC75B

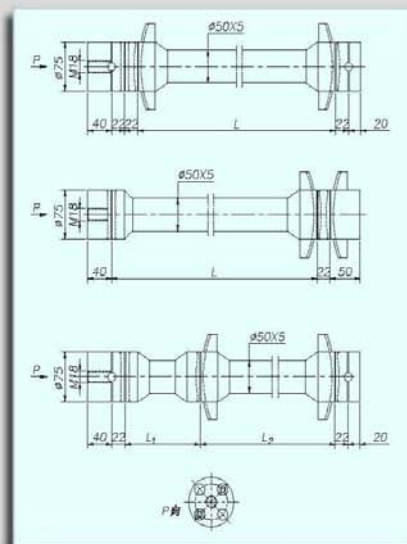

Fishery cable support system

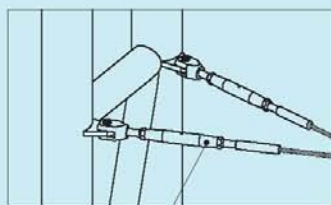
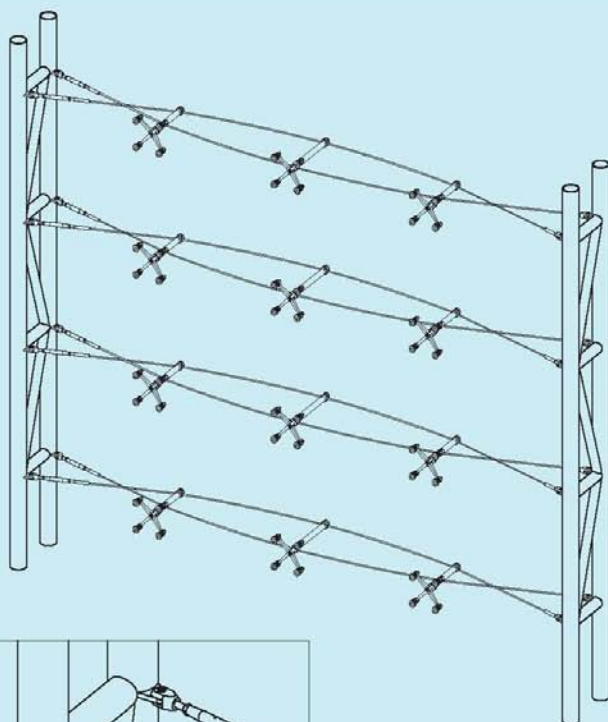

Turnbuckle

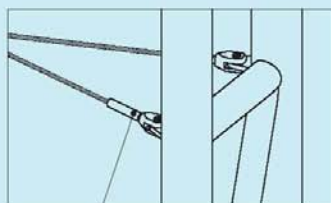

Fix Anchor

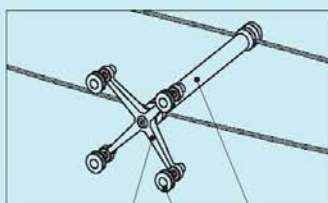

Spider

Strut

Route

IN ARCHITECTURAL GLASS FITTINGS

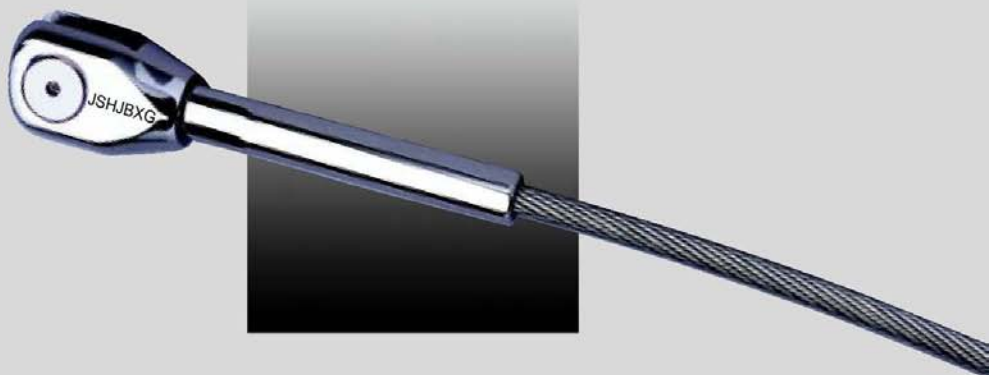

Cable with diameter 10 & below 10, the anchor would be hex



Cable with diameter 12 & above 12, the anchor would be round

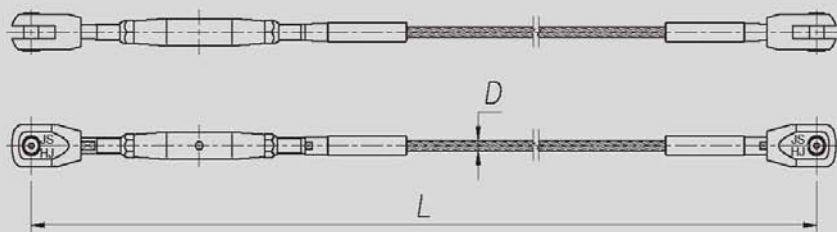

L is the length you ordered (pin to pin)

IN ARCHITECTURAL GLASS FITTINGS

S.S 316 and S.S 304 cable section area and mechanical properties

Cable structure	Cable Diameter (mm)	Wire Diameter (mm)	Cable section area (mm ²)	Wire breaking strength (N/mm ²)	Breaking Strength (KN)	Modules Elasticity (10 ³ MPa)
1 x 19	6.0	1.2	21.49	1320	25.53	0.9 ~ 1.25
	8.0	1.6	38.20		45.37	
	10.0	2.0	59.69		70.90	
	12.0	2.4	85.95		102.10	
	14.0	2.8	116.99		138.97	
	16.0	3.2	152.81		181.52	
1 x 37	18.0	2.6	192.15		220.39	1.25 ~ 1.45
	19.5	2.8	225.51		255.60	
	21.0	3.0	261.54		293.43	
1 x 61	22.5	2.5	299.43		309.76	
	24.0	2.7	340.69		363.55	
	26.0	2.9	399.84		421.66	
	28.0	3.1	463.72		484.0	
1 x 91	30.0	2.7	531.60		542.34	
	32.0	2.9	604.85		628.98	
	34.0	3.1	682.82		722.04	
	36.0	3.3	765.51		821.53	
	38.0	3.5	853.15		964.91	
	40.0	3.6	945.07	1068.87		
	42.0	3.8	1041.94	1178.43		
	44.0	4.0	1143.54	1243.60		
	46.0	4.2	1249.86	1359.22		
	48.0	4.4	1360.92	1420.80		
	50.0	4.5	1476.38	1541.34		

Note: In accordance with Chinese statutory regulation JGJ102-2003, Maximum design load = minimum breaking strength / 1.8 . However, the designer should use a design load with selected safety factor in compliance with the local government regulations in the respective country.



HSGP-04(Previous Model: HZC-1)

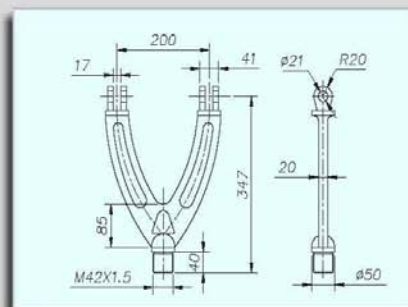

Fishtail tension rod support system

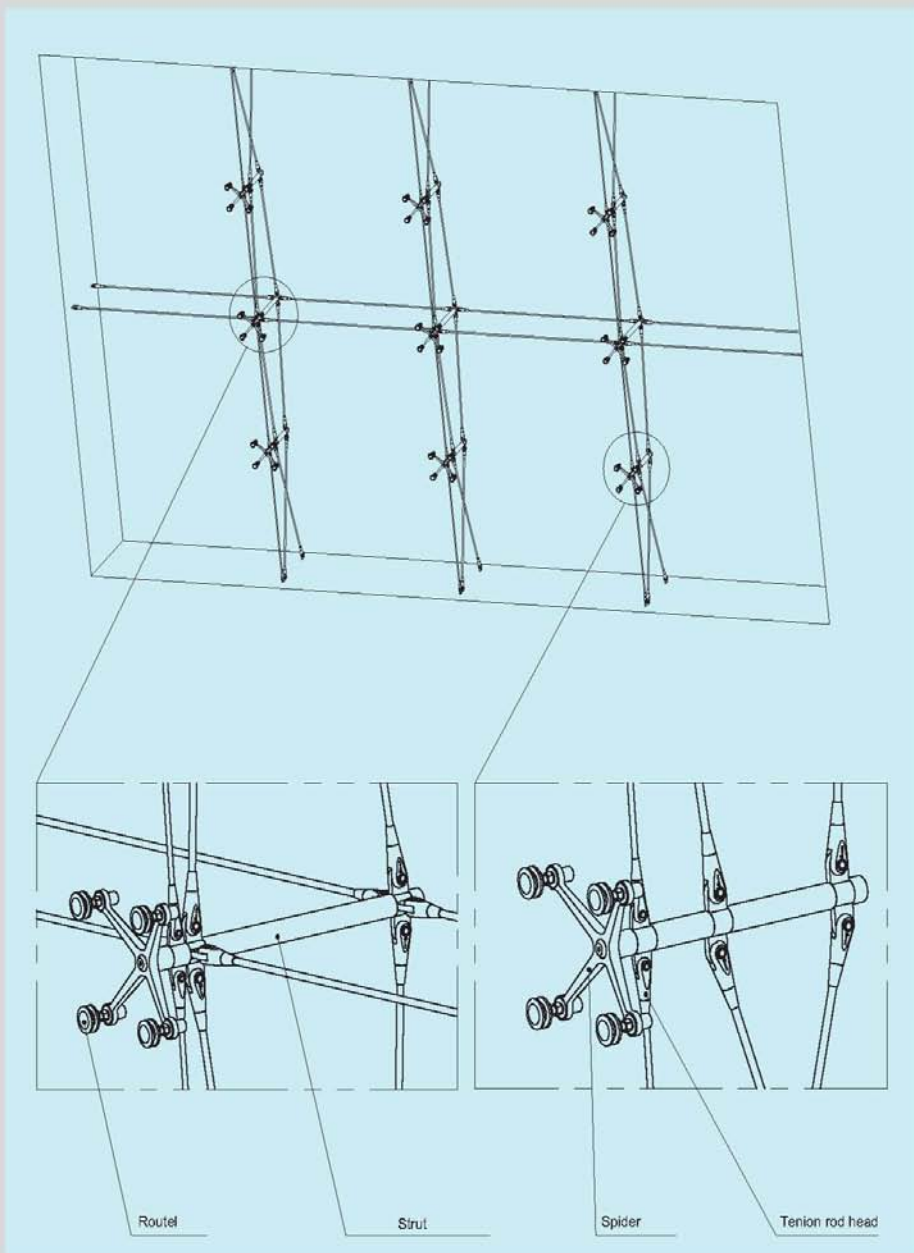

Application Patch Fitting Elevation to Tension rod system

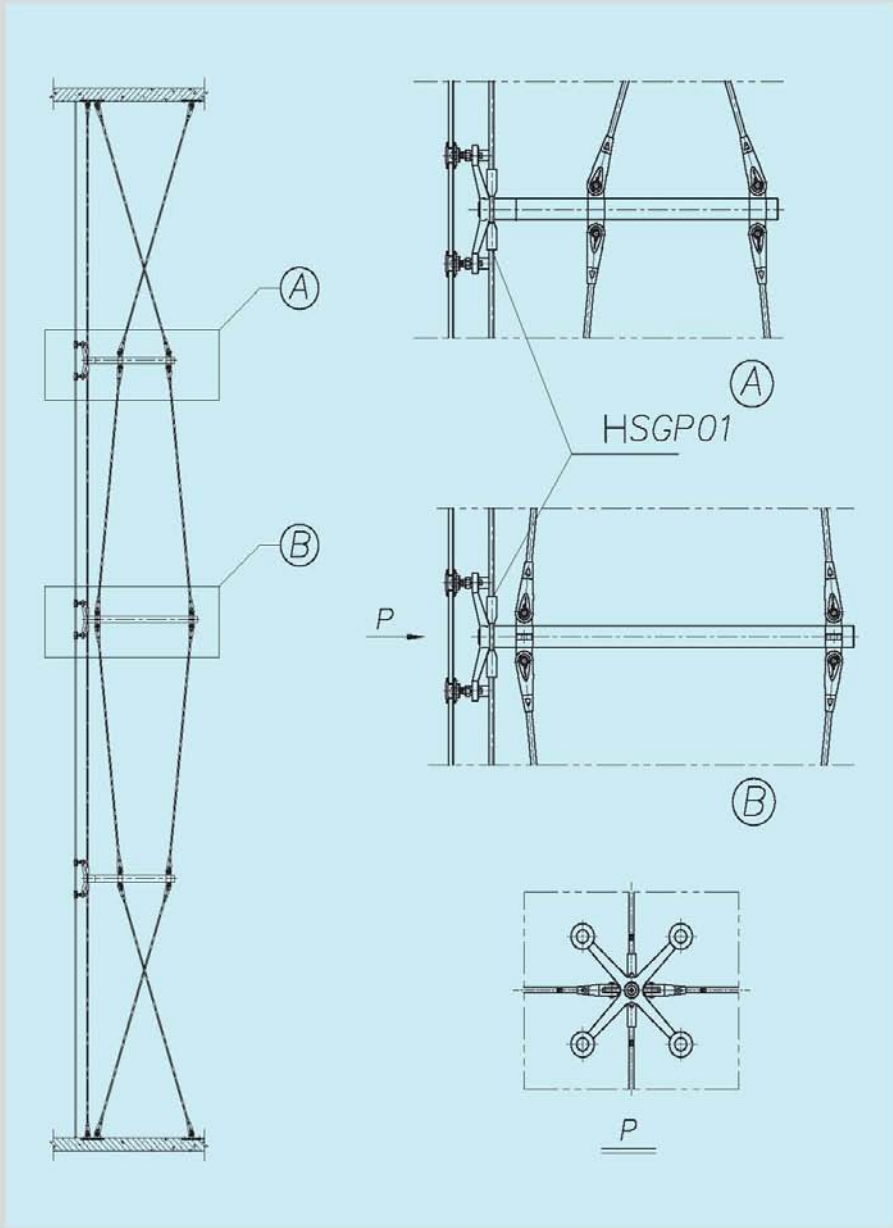

IN ARCHITECTURAL GLASS FITTINGS

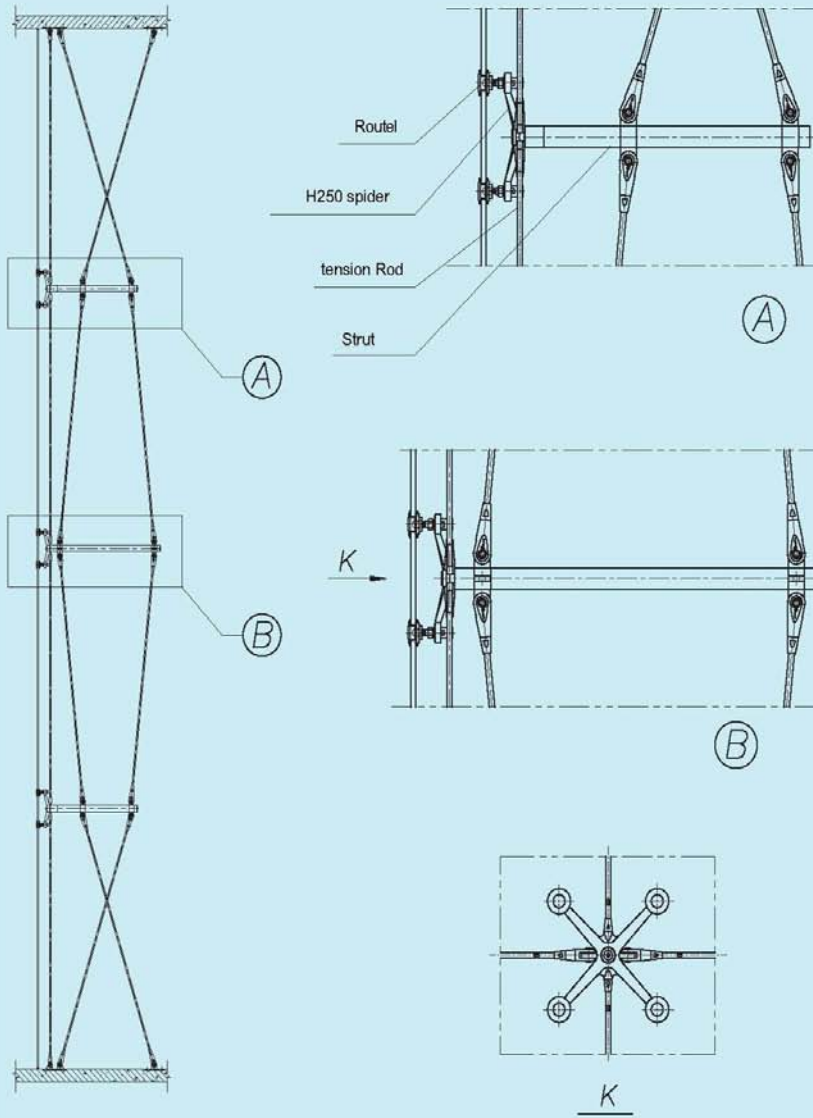

Cross-sectional areas of tension rods and mechanical properties

(Type A Standard thread) Materials : stainless steel 316 and 304

No.	Rod diameter, mm	Effective section area of rod, mm ²	Cross-sectional area of rod, mm ²	Yield Strength $\sigma_{0.2}$, MPa	Tensile Strength σ_b , MPa	Elongation δ , %
1	Ø8	36.608	50.265	250	625	≥20
2	Ø10	57.989	78.540			
3	Ø12	84.266	113.097			
4	Ø14	115.44	153.938			
5	Ø16	156.668	201.062			
6	Ø18	192.472	254.469			
7	Ø20	244.794	314.159			
8	Ø22	303.399	380.133			
9	Ø25	386.567	490.874			
10	Ø28	498.182	615.752			
11	Ø30	560.587	706.858			
12	Ø32	647.660	804.248			
13	Ø36	816.722	1017.876			

Note: In accordance with Chinese statutory regulation JGJ102-2003, Maximum design load = tensile strength / 1.4 . However, the designer should use a design load with selected safety factor in compliance with the local government regulations in the respective country.

(Type B Non-standard thread) Materials : stainless steel 316 and 304

No.	Rod diameter, mm	Effective section area of rod, mm ²	Cross-sectional area of rod, mm ²	Yield Strength $\sigma_{0.2}$, MPa	Tensile Strength σ_b , MPa	Elongation δ , %
1	Ø8	50.265	50.265	250	625	≥20
2	Ø10	78.540	78.540			
3	Ø12	113.097	113.097			
4	Ø14	153.938	153.938			
5	Ø16	201.062	201.062			
6	Ø18	254.469	254.469			
7	Ø20	314.159	314.159			
8	Ø22	380.133	380.133			
9	Ø25	490.874	490.874			

Note: In accordance with Chinese statutory regulation JGJ102-2003, Maximum design load = tensile strength / 1.4 . However, the designer should use a design load with selected safety factor in compliance with the local government regulations in the respective country.

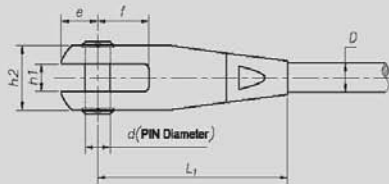
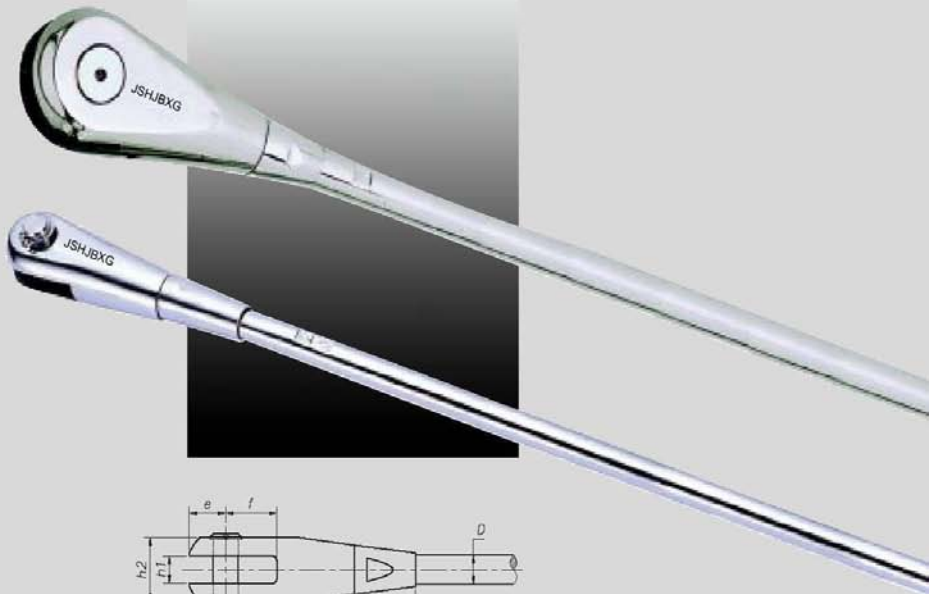

Tension rod head with diameter above 22mm

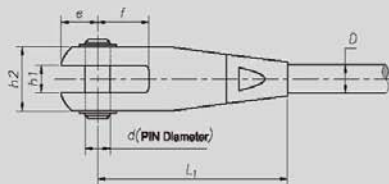

Tension rod head with diameter less than 22mm (spring clamp pin)

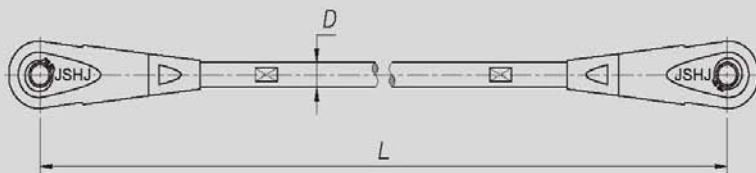

L is the length you ordered (pin to pin)

IN ARCHITECTURAL GLASS FITTINGS



TYPE MODE	D	e	f	h ₁	h ₂	L ₁	d	Single side adjustment
G01A-Ø12(10)	Ø12	18	23	11	26.5	100	Ø13	±12.5
G01A-Ø14	Ø14	20	25	13	31	108	Ø15	±12.5
G01A-Ø16	Ø16	23	28	15	35	117	Ø16	±12.5
G01A-Ø18	Ø18	25	35	17	40	130	Ø18	±12.5
G01A-Ø20	Ø20	30	35	17	42.5	138	Ø20	±14
G01A-Ø22	Ø22	32.5	42	21	47	148	Ø22	±14
G01A-Ø25	Ø25	38	48	21	53	170	Ø24	±15
G01A-Ø28	Ø28	42	52	25	60	182	Ø27	±15
G01A-Ø30	Ø30	46	60	25	65	195	Ø30	±15
G01A-Ø32	Ø32	49.5	65	27	68	205	Ø33	±17.5
G01A-Ø36	Ø36	56.5	72	29	76	220	Ø37	±17.5

Swaged end with adjustor

Model: HB05

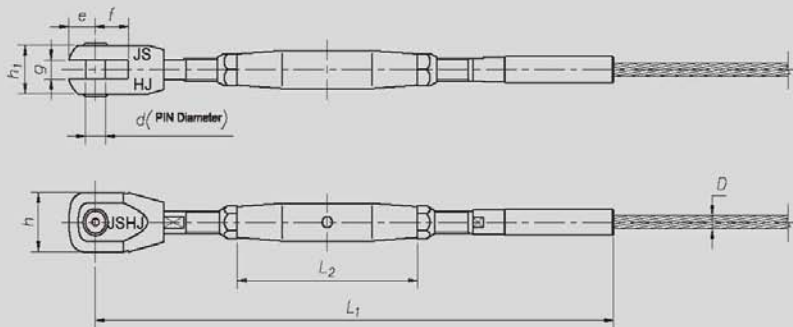
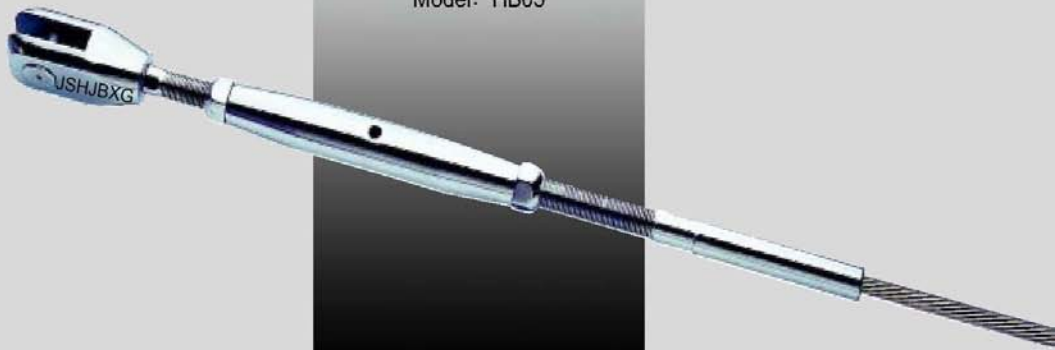

D	L₁	L₂	d	g	h₁	e	f	h
Ø6	≤ 370	125	15	11	30	19	28	38.5
Ø8	≤ 430	145	15	11	30	19	28	38.5
Ø10	≤ 495	165	16	15	35	24	28	45.5
Ø12	≤ 558	180	20	17	44	26.5	33	53.5
Ø14	≤ 615	195	22	21	52	31.5	35	60.5
Ø16	≤ 680	210	28	23	58	36	42	68
Ø18	≤ 775	240	31	25	62	43	50	80
Ø19.5	≤ 795	240	31	25	62	43	50	80
Ø21	≤ 860	260	34	25	70	45.5	60	84.5

Swaged end with adjustor

Model: HB05-E

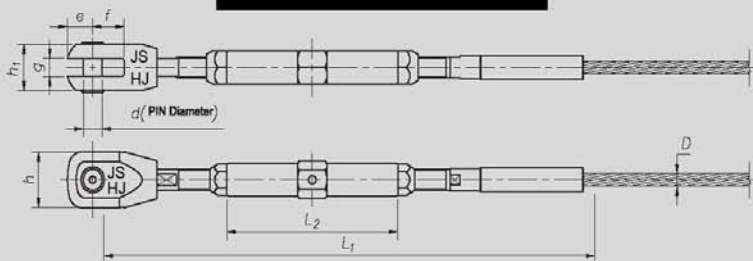

D	L ₁	L ₂	d	g	h ₁	e	f	h
Ø6	≤ 370	125	15	11	30	19	28	38.5
Ø8	≤ 430	145	15	11	30	19	28	38.5
Ø10	≤ 495	165	16	15	35	24	28	45.5
Ø12	≤ 558	180	20	17	44	26.5	33	53.5
Ø14	≤ 615	195	22	21	52	31.5	35	60.5
Ø16	≤ 680	210	28	23	58	36	42	68
Ø18	≤ 775	240	31	25	62	43	50	80
Ø19.5	≤ 795	240	31	25	62	43	50	80
Ø21	≤ 860	260	34	25	70	45.5	60	84.5
Ø22.5	≤ 895	260	36	28	72	48	60	89.5
Ø24	≤ 945	280	37	32	78	51.5	60	94.5
Ø26	≤ 1030	300	41	32	82	55.5	70	103
Ø28	≤ 1090	320	45	36	94	59	72	109
Ø30	≤ 1160	340	49	42	105	62.5	75	117.5
Ø32	≤ 1235	360	53	44	110	68.5	80	126.5
Ø34	≤ 1310	380	56	46	120	73.5	88	134
Ø36	≤ 1380	400	59	49	128	76	95	141.5

Swaged end with adjustor

Model: HB07

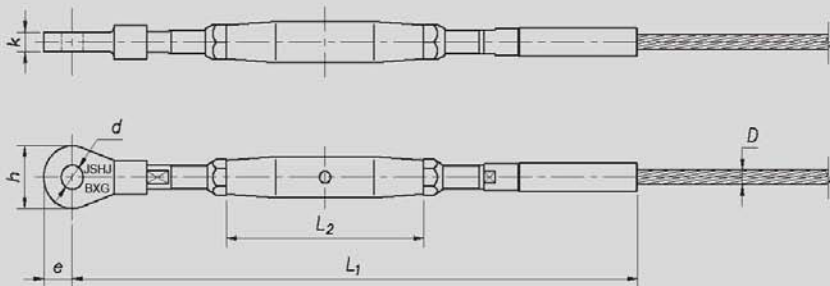

D	L ₁	L ₂	d	e	k	h
Ø6	≤ 380	125	13	18	10	36
Ø8	≤ 445	145	15	20	12	40
Ø10	≤ 510	165	17	23	14	46
Ø12	≤ 575	180	19	30	16	60
Ø14	≤ 640	195	23	35	20	70
Ø16	≤ 705	210	28	40	22	80
Ø18	≤ 800	240	31	38	28	76
Ø19.5	≤ 820	240	31	38	28	76
Ø21	≤ 880	260	34	40	28	80

Swaged end with adjustor

Model: HB09

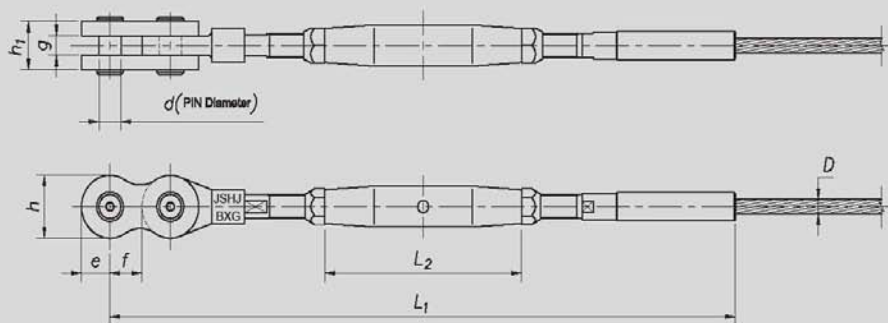

D	L ₁	L ₂	d	g	h ₁	h	e	f
Ø6	≤ 430	125	13	10	22	40	20	30
Ø8	≤ 500	145	15	12	24	44	22	33
Ø10	≤ 570	165	16	14	26	50	25	37
Ø12	≤ 645	180	18	16	32	60	30	40
Ø14	≤ 725	195	22	20	40	70	35	50
Ø16	≤ 800	210	28	22	46	80	40	55
Ø18	≤ 900	240	31	28	52	84	42	60
Ø19.5	≤ 920	240	31	28	52	84	42	60
Ø21	≤ 990	260	34	28	56	92	46	68

Swaged end with adjustor

Model: HB11

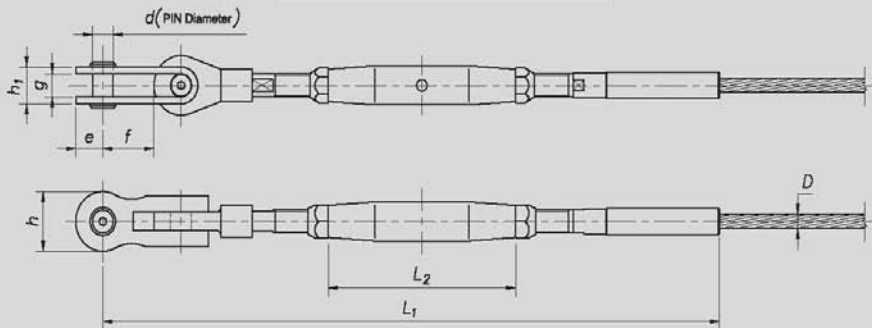

D	L ₁	L ₂	d	g	h ₁	h	e	f
Ø6	≤ 425	125	13	19	31	36	18	25
Ø8	≤ 495	145	15	21	33	40	20	30
Ø10	≤ 570	165	16	23	39	46	23	39
Ø12	≤ 650	180	18	25	41	56	28	46
Ø14	≤ 730	195	22	28	48	66	33	53
Ø16	≤ 800	210	28	35	59	80	40	56
Ø18	≤ 900	240	31	38	62	84	42	65
Ø19.5	≤ 920	240	31	38	62	84	42	65
Ø21	≤ 985	260	34	41	69	92	46	65

Swaged end

Model: HD06

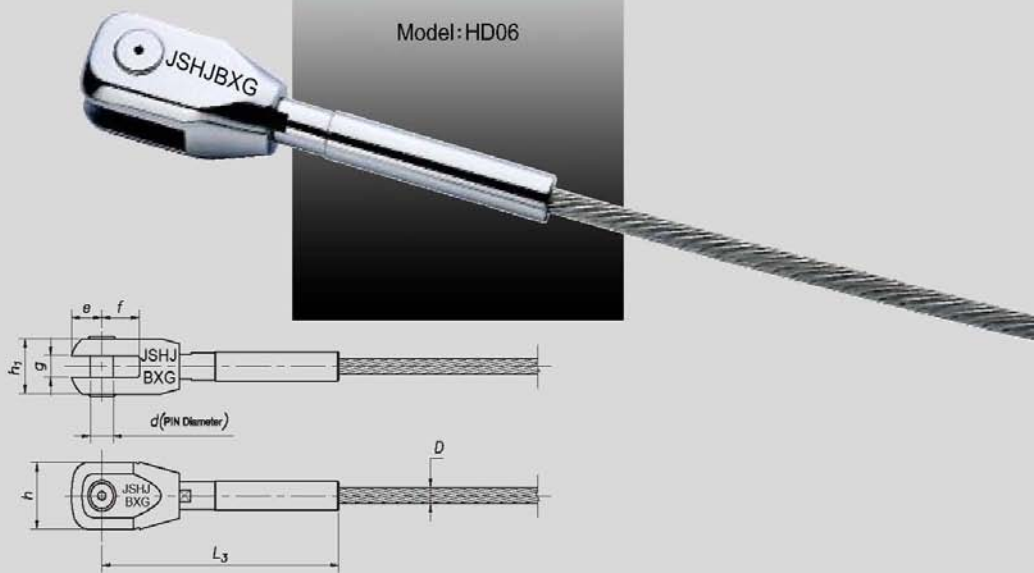

D	L ₃	d	g	h ₁	h	e	f
Ø6	120	15	11	30	38.5	19	28
Ø8	140	15	11	30	38.5	19	28
Ø10	165	16	15	35	45.5	24	28
Ø12	200	20	17	44	53.5	26.5	33
Ø14	225	22	21	52	60.5	31.5	35
Ø16	275	28	23	58	68	36	42
Ø18	305	31	25	62	80	43	50
Ø19.5	325	31	25	62	80	43	50
Ø21	355	34	25	70	84.5	45.5	60
Ø22.5	377	36	28	72	89.5	48	60
Ø24	395	37	32	78	94.5	51.5	60
Ø26	435	41	32	82	103	55.5	70
Ø28	462	42	36	94	109	59	72
Ø30	495	49	42	105	117.5	62.5	75
Ø32	525	53	44	110	126.5	68.5	80
Ø34	565	56	46	120	134	73.5	88
Ø36	595	59	49	128	141.5	76	95

Swaged end

Model: HD01

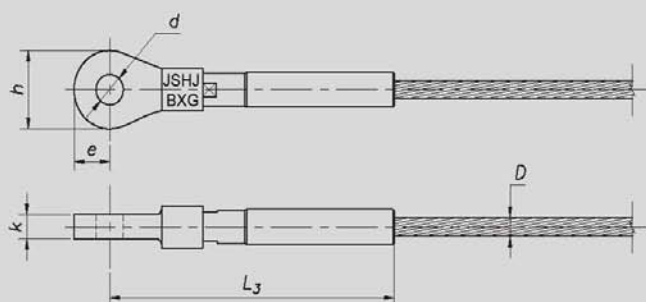
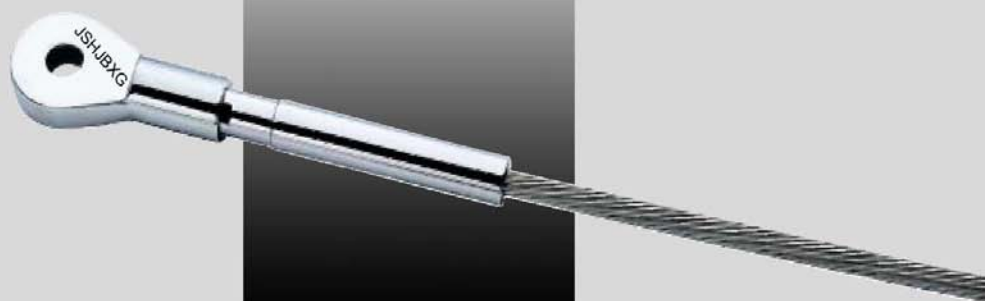

D	L ₃	k	h	d	e
Ø6	130	10	36	13	18
Ø8	155	12	40	15	20
Ø10	180	14	46	17	23
Ø12	220	16	60	19	30
Ø14	250	20	70	23	35
Ø16	300	22	80	28	40
Ø18	330	28	76	31	38
Ø19.5	350	28	76	31	38
Ø21	375	28	80	34	40

Swaged end

Model: HD02

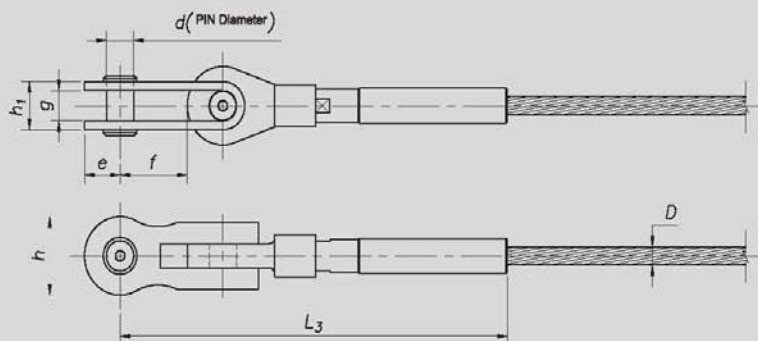

D	L ₃	d	g	h ₁	h	e	f
Ø6	175	13	19	31	36	18	25
Ø8	205	15	21	33	40	20	30
Ø10	240	16	23	39	46	23	39
Ø12	295	18	25	41	56	28	46
Ø14	340	22	28	48	66	33	53
Ø16	395	28	35	59	80	40	56
Ø18	430	31	38	62	84	42	65
Ø19.5	450	31	38	62	84	42	65
Ø21	480	34	41	69	92	46	65

Swaged end

Model: HD0S3

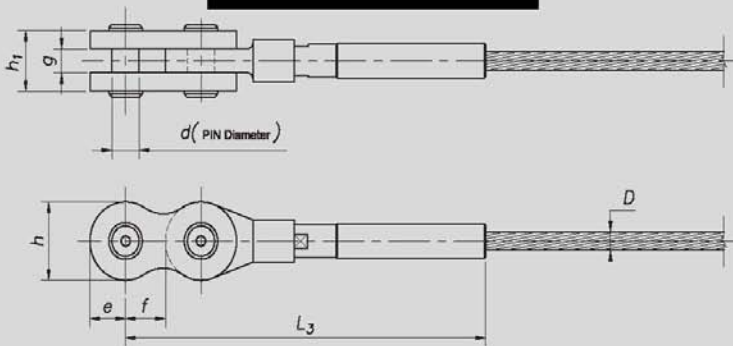

D	L ₃	d	g	h ₁	h	e	f
Ø6	180	13	10	22	40	20	30
Ø8	210	15	12	24	44	22	33
Ø10	240	16	14	26	50	25	37
Ø12	290	18	16	32	60	30	40
Ø14	335	22	20	40	70	35	50
Ø16	395	28	22	46	80	40	55
Ø18	430	31	28	52	84	42	60
Ø19.5	450	31	28	52	84	42	60
Ø21	485	34	28	56	92	46	68

Swaged end

Model: HE

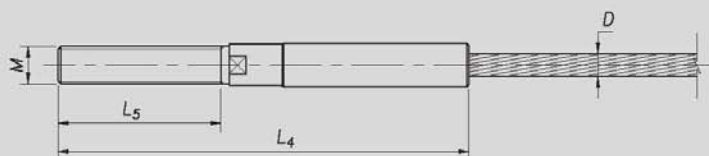

D	L ₄	L ₅	M
Ø6	145	72	M12
Ø8	175	82	M14
Ø10	205	92	M16
Ø12	240	105	M20
Ø14	270	115	M22
Ø16	315	125	M27
Ø18	355	145	M30
Ø19.5	375	145	M30
Ø21	400	155	M33

D	L ₄	L ₅	M
Ø22.5	422	155	M33
Ø24	440	160	M36
Ø26	480	175	M39
Ø28	510	185	M42
Ø30	545	192	M45
Ø32	580	208	M48
Ø34	615	215	M52
Ø36	650	230	M56

Swaged end with adjustor

Model: HG01

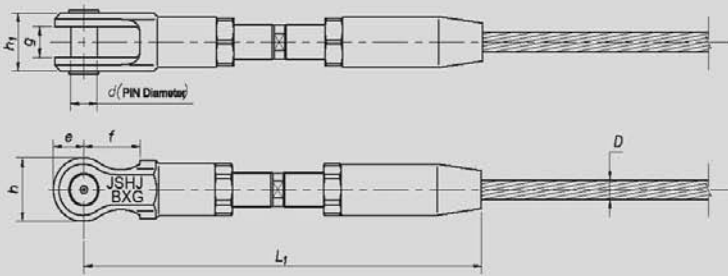
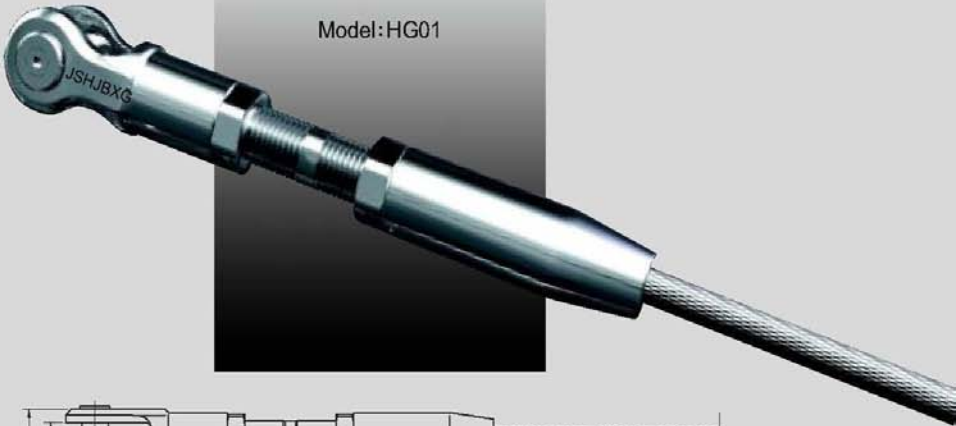

D	L ₁	d	g	h ₁	e	f	h
Ø30	≤930	Ø50	54	104	55	98	102
Ø32	≤952	Ø54	56	106	57	102	108
Ø34	≤970	Ø58	58	112	62	108	118
Ø36	≤986	Ø60	65	121	65	110	124
Ø38	≤1020	Ø62	68	124	72	115	132
Ø40	≤1020	Ø66	70	130	75	120	138
Ø42	≤1055	Ø68	72	134	78	130	146
Ø44	≤1070	Ø70	74	136	81	130	152
Ø46	≤1090	Ø72	76	142	83	140	156
Ø48	≤1130	Ø74	78	146	85	150	160
Ø50	≤1170	Ø76	80	150	87	160	164

IN ARCHITECTURAL GLASS FITTINGS

Swaged end

Model: HH01

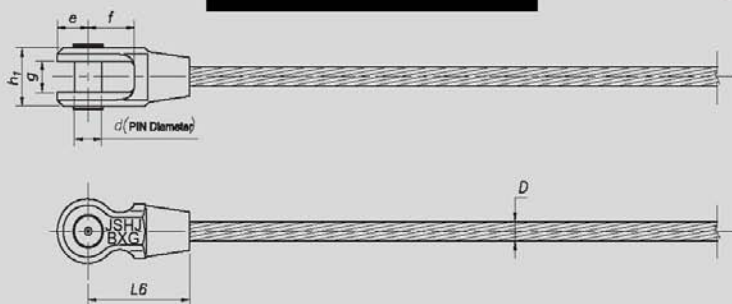
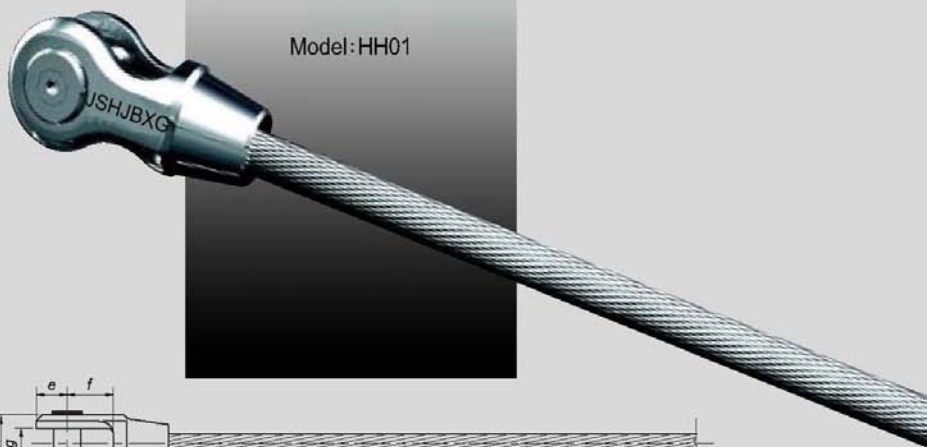

D	L ₆	d	g	h ₁	e	f	h
Ø30	166	Ø50	54	104	55	68	102
Ø32	176	Ø54	56	106	57	72	108
Ø34	190	Ø58	58	112	62	78	118
Ø36	196	Ø60	65	121	65	80	124
Ø38	210	Ø62	68	124	72	87	132
Ø40	230	Ø66	70	130	75	92	138
Ø42	240	Ø68	72	134	78	100	146
Ø44	250	Ø70	74	136	81	100	152
Ø46	260	Ø72	76	142	83	108	156
Ø48	273	Ø74	78	146	85	117	160
Ø50	287	Ø76	80	150	87	130	164

Swaged end

Model: HK01



D	L ₄	L ₅	M
Ø30	450	225	56
Ø32	475	233	60
Ø34	475	233	62
Ø36	485	236	65
Ø38	505	243	70
Ø40	520	248	72
Ø42	530	248	76
Ø44	550	252	80
Ø46	560	252	82
Ø48	585	255	85
Ø50	615	270	90

